

OIL BREATHER

The oil breather code 17 15 57 50 appearing in the parts catalogues for the 850 T3 (and different versions) - V 1000 I CONVERT - V 1000 G5 - 1000 SP, table 2 - position 3, has been cancelled and replaced with the new type code 17 15 57 51.

The modification has been made to improve the operation of the oil breather unit; we suggest to carry out the same modification also on the motorcycles previously produced, acting as follows:

- remove the air filter unit from the bike and take out the breather from the intake manifold;
- cut the "T" end (see "A") of the breather tube according to the dimensions (see "B") indicated in the drawing;
- when this has been done, clean everything with gasoline and dry with compressed air. Reassemble the breather and air filter in the manifold.

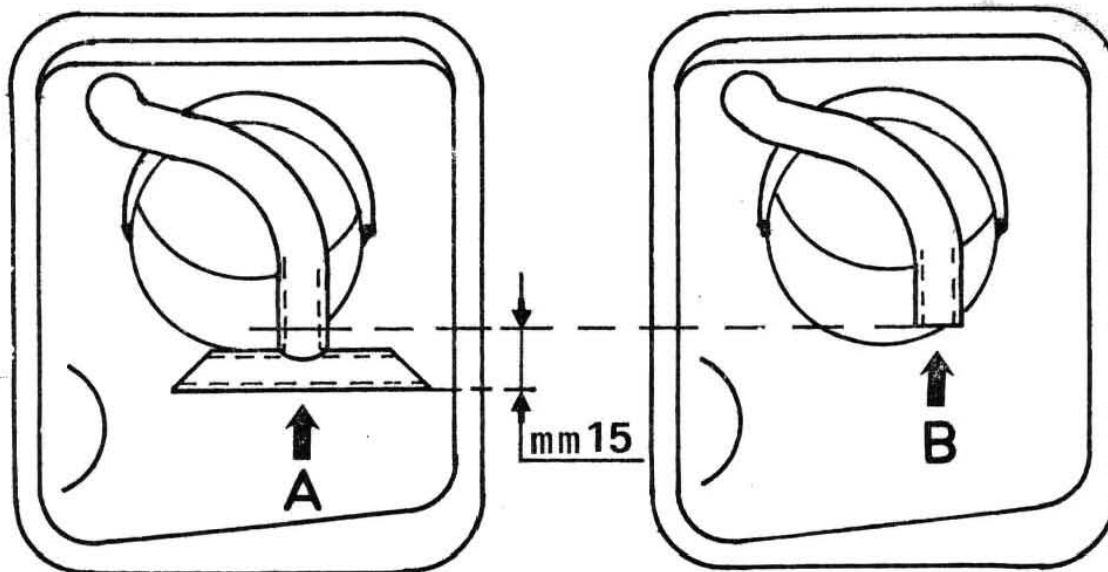

BREATHER UNIT PRIOR TO  
MODIFICATION

code 17 15 57 50

BREATHER UNIT MODIFIED

code 17 15 57 51