



part# 06.90.00.01



GRISO

USE+MAINTENANCE BOOK

First edition: March 2006

Reprint:

Produced and printed by:
VALLEY FORGE DECA
Ravenna , Modena, Torino
DECA S.r.l.
Registered Main Office
Via Vincenzo Giardini, 11
48022 Lugo (RA) - Italy
Tel. +39 - 0545 216611
Fax +39 - 0545 216610
E-mail: deca@vftis.spx.com
www.vftis.com

On behalf of:
Moto Guzzi S.p.A.
via E. V. Parodi, 57
23826 Mandello del Lario (LECCO) - Italia
Tel. +39 - 0341 70 91 11
Fax +39 - 0341 70 92 20
www.motoguzzi.it

FOREWORD

NOTE This manual is an important and integral part of your vehicle. Keep it with your vehicle at all times, even if your vehicle is resold.

Moto Guzzi has prepared this manual to supply you, the user, with correct and current information. However, since **Moto Guzzi** constantly improves the design of its vehicles, there may be slight discrepancies between your vehicle and the material given in this manual. If you have any questions about your vehicle, contact your local **Moto Guzzi** Dealer, as he will have the very latest technical information available from the factory.

For tests and repairs not expressly described in this manual, to purchase **Moto Guzzi** genuine spare parts, accessories, and other products, and for help with specific problems, please contact your Local **Moto Guzzi** Dealer or service center. These professionals will be able to assist you promptly and efficiently.

Thank you for choosing **Moto Guzzi**. Have a great ride!

This manual is copyrighted in all countries, and reproduction thereof in full or in part by any print or electronic means is strictly prohibited.

INTRODUCTION

This manual is divided by subject into sections, chapters and paragraphs. The procedures described are laid out step by step, and each operation is indicated by a ♦.

The numbered parts shown in the figures are identified in the text by the number in parentheses or the symbol representing them.

Example (the following text is generic and does not refer to this specific vehicle):

section

MAIN INDEPENDENT CONTROLS

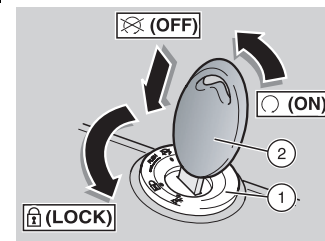

chapter

STEERING LOCK

safety
warning

⚠ WARNING

Never attempt to place the ignition switch in the locked "a" (LOCK) position while the vehicle is moving.

paragraph

OPERATION

operation

To lock the steering:

- ♦ Turn the handlebar completely to the left or to the right.

position (2)

- ♦ Turn the key (2) to position "a".

symbol "a"

- ♦ Press the key and turn it to position "a".
- ♦ Remove the key.

SAFETY WARNINGS

The following precautionary warnings are used throughout this manual in order to convey the following messages:

 **Safety Warning: When you see this symbol on the vehicle or in the manual, pay particular attention to the potential risk of personal injury or death. Failure to comply with the instructions given in the warning messages preceded by this symbol may result in grave risk for your and other people's safety and for the vehicle.**

WARNING

Indicates a potential hazard which may result in serious injury or even death.

WARNING

Indicates a potential hazard which may result in personal injury or damage to the vehicle or other property.

NOTE The word "NOTE" in this manual precedes important information or instructions.

GENERAL SAFETY RULES

CARBON MONOXIDE

If it is necessary to run the engine in order to carry out maintenance operation, make sure that the area in which you are operating is properly ventilated. Never run the engine in enclosed spaces.

If it is necessary to work indoors, use an exhaust evacuation system.

WARNING

The exhaust fumes contain carbon monoxide, a poisonous gas that can cause loss of consciousness and even death.

WARNING

Carbon monoxide is both colorless and odorless, and cannot be detected by smell, vision, or any other sense. Avoid breathing exhaust fumes in all circumstances.

GASOLINE

Keep gasoline away from children. Gasoline is also poisonous. Never attempt to siphon gasoline using your mouth. Never allow gasoline to contact your skin. If you should accidentally spill gasoline on yourself, change your clothes immediately and wash the area thoroughly where the gasoline was splashed with soap and hot water. Should you accidentally swallow gasoline, do not induce vomiting. Drink large quantities of clear water or milk and immediately seek professional medical assistance. Should you accidentally get gasoline in your eyes, flush with large quantities of cool, clear water and immediately seek professional medical assistance.

WARNING

Gasoline is extremely flammable and becomes explosive under certain conditions.

KEEP GASOLINE AWAY FROM CHILDREN.

HOT COMPONENTS

WARNING

The engine and all parts of the exhaust system, as well as the braking system, become very hot and stay hot for some time after the vehicle and the engine are stopped. Before handling any component of your vehicle after riding, make sure that it has cooled sufficiently to be safe to handle.

USED ENGINE OIL

WARNING

Use latex gloves for maintenance operations that require contact with used oil. Used engine oil may cause skin cancer if repeatedly left in contact with the skin for prolonged periods. Although this is unlikely unless you handle used oil on a daily basis, it is advisable to thoroughly wash your hands with soap and water after handling used oil.

KEEP OIL AWAY FROM CHILDREN.

BRAKE FLUID

WARNING

Brake fluid is extremely poisonous. Never ingest or swallow brake fluid. Should brake fluid accidentally be swallowed, drink large quantities of milk or clear water and immediately seek professional medical assistance. Brake fluid is highly destructive of skin and eye tissue. Should you accidentally spill brake fluid on yourself, remove the contaminated clothing, wash your body with soap and warm water immediately and immediately seek professional medical assistance. Should you accidentally splash brake fluid into your eyes, flush with a large quantity of cool, clear water and immediately seek professional medical assistance.

KEEP BRAKE FLUID AWAY FROM CHILDREN.

CLUTCH FLUID

CAUTION

Clutch fluid is extremely poisonous. Never ingest or swallow clutch fluid. Should clutch fluid accidentally be swallowed, drink large quantities of milk or clear water and immediately seek professional medical assistance. Clutch fluid is highly destructive of skin and eye tissue. Should you accidentally spill clutch fluid on yourself, remove the contaminated clothing, wash your body with soap and warm water immediately and immediately seek professional medical assistance. Should you accidentally splash clutch fluid into your eyes, flush with a large quantity of cool, clear water and immediately seek professional medical assistance.

KEEP CLUTCH FLUID AWAY FROM CHILDREN.

COOLANT

In certain conditions, the ethylene glycol contained in the engine coolant is flammable; its flame is invisible, but you can be burned anyway.

WARNING

Avoid spilling the engine coolant on the exhaust system or on the engine components. They may be hot enough to cause the coolant to ignite and burn without a visible flame.

The coolant (ethylene glycol) can cause skin irritation and is poisonous if swallowed.

Coolant and coolant/water mixtures are sweet to the taste and brightly colored, therefore highly attractive to pets and children. Take extra precautions to keep new and used coolant out of reach of children and animals.

KEEP COOLANT AWAY FROM CHILDREN.

Risk of burns.

Do not remove the radiator cap when the engine is hot. Wait until the engine has completely cooled down. The coolant is under pressure and may splash out and cause burns.

BATTERY HYDROGEN GAS AND ELECTROLYTE

WARNING

The battery gives off noxious and explosive gases; keep cigarettes, flames and sparks away from the battery. Provide adequate ventilation when operating or recharging the battery.

The electrolyte is poisonous.

If the electrolyte is accidentally swallowed, drink large quantities of water or milk and then milk of magnesia or vegetable oil. Immediately consult a health professional.

KEEP BATTERIES AND ELECTROLYTE AWAY FROM CHILDREN.

WARNINGS - PRECAUTIONS - GENERAL ADVICE

Before starting the engine, read this manual carefully, in particular the chapters "WARNINGS - PRECAUTIONS - GENERAL ADVICE" and "SAFE DRIVE" see p. 17.

Your safety and that of those around you depends not only on your skill as a rider, but also your knowledge of your vehicle and about riding safely. Therefore it is essential that you not operate your vehicle on public streets or highways until you have received instructions from a qualified safety organization such as the Motorcycle Safety Foundation, and until you are properly trained and licensed.

REPORTING DEFECTS THAT AFFECT SAFETY

If you believe that your vehicle has a defect which could cause a crash or could cause injury or death, you should immediately inform the National Highway Traffic Safety Administration (NHTSA), in addition to notifying **Moto Guzzi**. If NHTSA receives similar complaints, it may open an investigation, and if it finds that a safety defect exists in a group of vehicles, it may order a recall and remedy campaign. However, NHTSA cannot become involved in individual problems between you, your dealer or **Moto Guzzi**. To contact NHTSA, you may either call the **Auto Safety Hotline** toll free at 1-800-424-9393 (or 366-0123 in the Washington, D.C. area) or write to: NHTSA, U.S. Department of Transportation, Washington, D.C. 20590.

You can also obtain other information about motor vehicle safety from the Hotline.

ROAD REGULATIONS AND USING THE VEHICLE

Road regulations vary from country to country. It is essential that you understand in advance the regulations of the country in which your vehicle will be used.

WARNING

This vehicle has been designed and built for use on paved roads only. It is not designed to be used on even smooth, graded dirt roads or trails. It is not designed for off road competition, or for cross country riding. Do not use this vehicle on rough or unmaintained surfaces, or in other off road areas. Failure to heed this warning could lead to an undesirable accident with subsequent injury and even death.

NOISE EMISSION WARRANTY

Moto Guzzi s.p.a. guarantees that this exhaust system, at the time of sale, meets all applicable U.S. **EPA** Federal noise standards. This warranty extends to the first person who buys this exhaust system for purposes other than resale, and to all subsequent buyers.

Warranty claims should be directed to:

Moto Guzzi USA

140 East 45th Street, 17th Floor
New York, NY 10017
Tel: 877.277.4552 (877.Aprilia)
Fax: 001.212.380.4459

INFORMATION ON THE NOISE AND EXHAUST GAS EMISSION CONTROL SYSTEM

ORIGIN OF THE EMISSIONS

The combustion process produces carbon monoxide and hydrocarbons. The control of hydrocarbons is very important, because under certain conditions they react to exposure to sunlight and produce photochemical smog.

Carbon monoxide does not react in the same way, but it is toxic and poisonous. **Moto Guzzi** utilizes "lean" carburetor settings and other systems to reduce the production of carbon monoxide and hydrocarbons.

TAMPERING WARNING

Tampering with the noise control system is prohibited. Federal law prohibits the following acts or causing thereof:

- The removal or rendering inoperative by any person other than for purposes of maintenance, repair, or replacement, of any device or element of design incorporated into any new vehicle for the purpose of noise control prior to its sale or delivery to the ultimate purchaser or while it is in use, or
- Use of the vehicle after such device or element of design has been removed or rendered inoperative by any person.

Among those acts presumed to constitute tampering are those listed below:

- Removal or puncturing of the muffler, baffles, header pipes or any other component conducting exhaust gases.
- Removal or puncturing of any part of the intake system.
- Lack of proper maintenance.
- Replacing any moving part of the vehicle, or parts of the exhaust or intake system, with parts other than those specified by the manufacturer.

CAUTION

This product should be checked for repair or replacement if the vehicle noise has increased significantly through use. Otherwise, the owner may become subject to penalties under state and local ordinances.

PROBLEMS THAT MAY AFFECT VEHICLE EMISSIONS

If any of the following symptoms are observed, have your vehicle immediately inspected and repaired by your Local **Moto Guzzi** Dealer

Symptoms:

- Difficult starting or stalling after starting.
- Irregular idle.
- Misfiring or backfiring during acceleration.
- After-burning (backfiring).
- Poor engine performance, impaired handling or poor fuel economy.

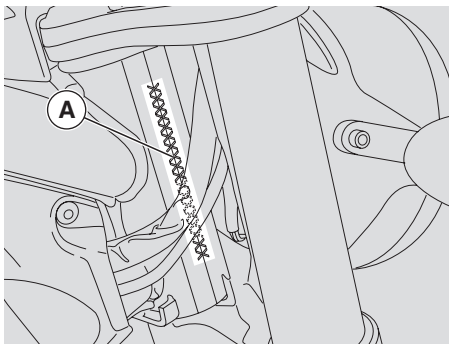

VEHICLE IDENTIFICATION NUMBER (V.I.N.) (FRAME NUMBER)

Every vehicle produced by **Moto Guzzi** receives a vehicle identification number (V.I.N.) stamped:

- on the steering head of the frame (A), as shown above;
- and also:
- on the identification plate (B) located on the front portion near the steering head of the frame.

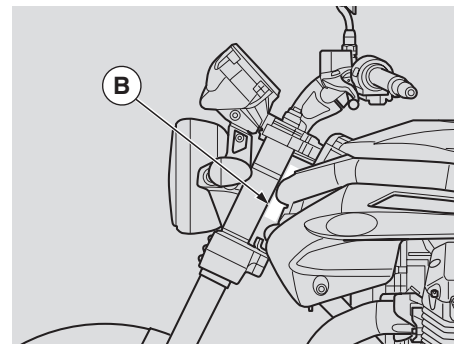

INFORMATION CONTAINED IN THE VEHICLE IDENTIFICATION NUMBER

Description of the vehicle identification number (V.I.N.) stamped on the steering head of the frame (A) and on the identification plate (B).



○ MFD BY Moto Guzzi S.p.A. Italy ○

THIS VEHICLE CONFORMS TO ALL
APPLICABLE U.S. FEDERAL MOTOR VEHICLE
SAFETY STANDARDS IN EFFECT ON THE
DATE OF MANUFACTURE SHOWN ABOVE

○ GVWR 450 KG (991 LB)
GAWR F. 170 KG (374 LB)
WITH 120/70 ZR17 (58W) TIRE
AND E17 x 3.50 DOT RIM
AT 230 KPA (33 PSI) COLD
GAWR R. 280 KG (617 LB)
WITH 180/55 ZR17 (73W) TIRES
AND E17 x 5.50 DOT RIM
AT 250 KPA (36 PSI) COLD ○

VIN:

○ TYPE: MOTORCYCLE ○

DIGIT MEANING

- 1) Manufacturer's identification alphanumeric code.
- 2) Vehicle type.
- 3) Model.
- 4) Country for which the vehicle is intended.
- 5) # = Check digit number.
- 6) Model year (Y).
- 7) Assembling factory designation (M = MANDELLO).
- 8) Sequential serial number.

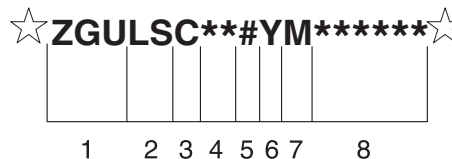

POSITION OF THE WARNING ADHESIVE LABELS

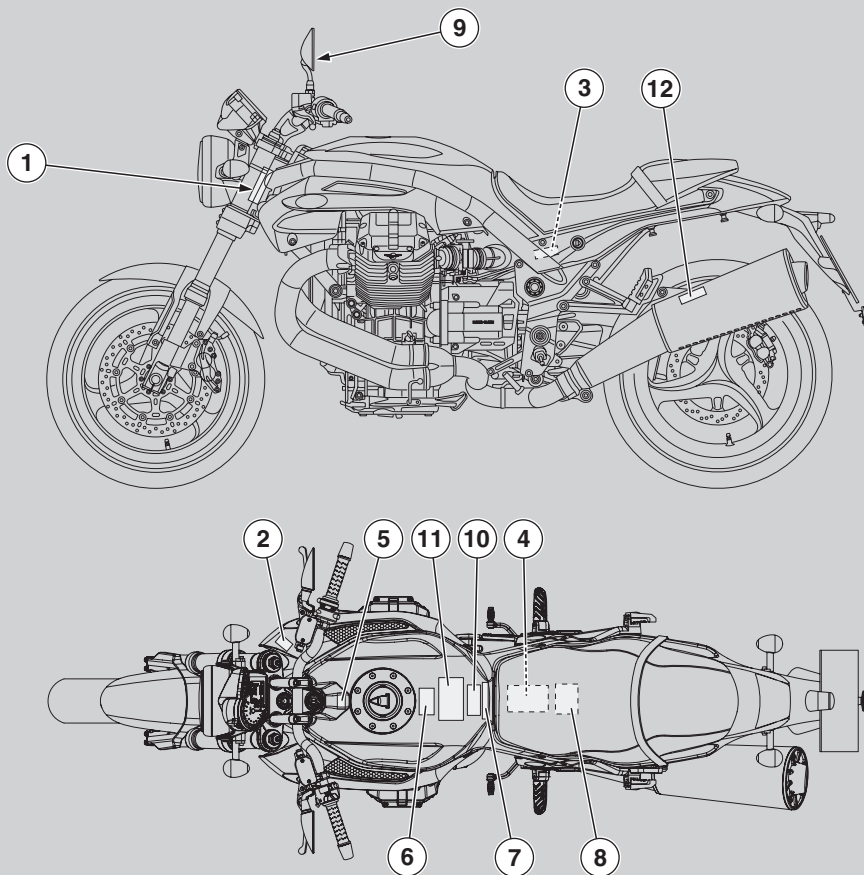

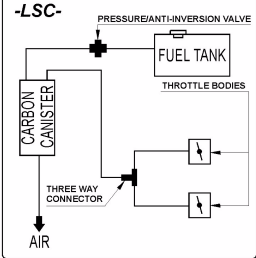

WARNING ADHESIVE LABELS CHART

Ref.	Description
1	<p>○MFD BY Moto Guzzi S.p.A. Italy○</p> <p>GWWR 450 KG (991 LB) GAWR F. 170 KG (374 LB) WITH 120/70 ZR17 (58W) TIRE AND E17 X 5.50 DOT RIM AT 230 KPA (33 PSI) COLD GAWR R. 280 KG (617 LB) WITH 180/55 ZR17 (73W) TIRES AND E17 X 5.50 DOT RIM AT 250 KPA (36 PSI) COLD</p> <p>THIS VEHICLE CONFORMS TO ALL APPLICABLE U.S. FEDERAL MOTOR VEHICLE SAFETY STANDARDS IN EFFECT ON THE DATE OF MANUFACTURE SHOWN ABOVE</p> <p>VIN: _____</p> <p>○ TYPE: MOTORCYCLE ○</p>
2	<p>MOTO GUZZI S.p.A. </p> <p>EVAP FAMILY: 7MGXE0024LSC</p> <p>HOSE ROUTING DIAGRAM</p> <p>-LSC-</p>  <p>PRESSURE/ANTI-INVERSION VALVE</p> <p>FUEL TANK</p> <p>THROTTLE BODIES</p> <p>CARBON CANISTER</p> <p>THREE WAY CONNECTOR</p> <p>AIR</p>
3	<p>⚠ WARNING!</p> <ul style="list-style-type: none"> ● CONTAINS HIGH PRESSURE NITROGEN GAS. ● SEE WORKSHOP MANUAL FOR DISPOSAL AND ADJUSTING UNIT. ● DO NOT OPEN. DO NOT INCINERATE. INCINERATION, PUNCTURE OR DISASSEMBLY MAY CAUSE THIS UNIT TO EXPLODE.

Ref.	Description																							
4	<p>⚠ WARNING!</p> <p>Do not use any tire other than those recommended and approved by Moto Guzzi. Maintain proper tire inflation. Do not use any tire with less than 1/8" (3mm) tread remaining. Do not repair any tire, nor use a repaired tire. Do not ride your motorcycle overloaded or with an unbalanced load. Failure to follow these warnings can lead to an accident and serious injuries or death. See owner's manual.</p> <p>-LSC- </p> <table border="1"> <thead> <tr> <th colspan="2">Tires pressure</th> <th rowspan="2">kg</th> <th rowspan="2">lb</th> <th rowspan="2">Tire</th> </tr> <tr> <th>Front</th> <th>Rear</th> </tr> </thead> <tbody> <tr> <td>230 (33)</td> <td>250 (36)</td> <td rowspan="2">120/70-ZR17 (58W)</td> <td rowspan="2">}</td> <td>Front tire</td> </tr> <tr> <td>230 (33)</td> <td>250 (36)</td> <td>Metzler Michelin Dunlop Pirelli</td> </tr> <tr> <td>230 (33)</td> <td>250 (36)</td> <td rowspan="2">180/55-ZR17 (73W)</td> <td rowspan="2">}</td> <td>Rear tire</td> </tr> <tr> <td>230 (33)</td> <td>250 (36)</td> <td>Metzler Michelin Dunlop Pirelli</td> </tr> </tbody> </table>	Tires pressure		kg	lb	Tire	Front	Rear	230 (33)	250 (36)	120/70-ZR17 (58W)	}	Front tire	230 (33)	250 (36)	Metzler Michelin Dunlop Pirelli	230 (33)	250 (36)	180/55-ZR17 (73W)	}	Rear tire	230 (33)	250 (36)	Metzler Michelin Dunlop Pirelli
Tires pressure		kg	lb				Tire																	
Front	Rear																							
230 (33)	250 (36)	120/70-ZR17 (58W)	}	Front tire																				
230 (33)	250 (36)			Metzler Michelin Dunlop Pirelli																				
230 (33)	250 (36)	180/55-ZR17 (73W)	}	Rear tire																				
230 (33)	250 (36)			Metzler Michelin Dunlop Pirelli																				
5	<p>⚠ WARNING!</p> <p>DO NOT ALLOW KEY CHAIN AND ANY OTHER ITEM TO FALL BETWEEN THE STEERING HEAD AND THE BODY OF MOTORCYCLE. THIS CAN CAUSE LOSS OF CONTROL.</p>																							
6	<p>⚠ WARNING!</p> <ul style="list-style-type: none"> • Wear a helmet, eye protection, and bright protective clothing. • Don't ride after consuming alcohol or other drugs. • Slow down on slippery surface, unfamiliar terrain or when visibility is reduced. • Read owner's manual carefully • Failure to follow these warnings can lead to an accident and serious injuries or death. • USE UNLEADED FUEL. MINIMUM OCTANE RATING (R + M) / 2 METHOD 90. • See owner's manual for the correct running in and maintenance of the vehicle. 																							
7	<p>⚠ WARNING!</p> <p>Never install accessories or replacement parts not approved by Aprilia as original equipment. This can degrade the handling and safety of your motorcycle, and can cause an upset with subsequent accident and serious injury or even death. The stability and safety of any motorcycle is adversely affected by the addition of any load carrying accessory. See owner's manual.</p>																							

Follow ►

Ref.	Description
8	<div style="border: 1px solid black; padding: 5px;"> <p style="text-align: center;">⚠ WARNING!</p> <p>Contain sulfuric acid which can cause severe injuries. Avoid contact with skin, eyes or clothing. Antidote: EXTERNAL - Flush with water. INTERNAL - Drink large quantities of water or milk. Follow with milk of magnesia, beaten egg or veg. oil. Call physician immediately. Eyes: Flush with water for 15 minutes and get prompt medical attention.</p> <p>KEEP OUT OF REACH OF CHILDREN.</p> <p>Batteries produce explosive gases. Keep sparks, flames, cigarettes away. Charge only in well-ventilated space. Always wear protective goggles when working around batteries. Always connect the battery vent tube. Failure to heed this warning will cause corrosion of the electrical system.</p> </div>
9	<div style="border: 1px solid black; padding: 5px; text-align: center;"> <p>OBJECTS IN MIRROR ARE CLOSER THAN THEY APPEAR.</p> </div>
10	<div style="border: 1px solid black; padding: 5px;"> <p style="text-align: center;">MOTORCYCLE NOISE EMISSION CONTROL INFORMATION</p> <p>THIS 2007 GUZLSC1064 MOTORCYCLE, ZGU1001 MEETS EPA NOISE EMISSION REQUIREMENTS OF 80 dBA AT 4180 closing r.p.m. BY FEDERAL TEST PROCEDURE. MODIFICATIONS WHICH CAUSE THIS MOTORCYCLE TO EXCEED FEDERAL NOISE STANDARDS ARE PROHIBITED BY FEDERAL LAW. SEE OWNER'S MANUAL.</p> <p style="text-align: center;">-LSC- </p> </div>
11	<div style="border: 1px solid black; padding: 5px;"> <p style="text-align: center;">VEHICLE EMISSION CONTROL INFORMATION -LSC-</p> <p>ENGINE DISPLACEMENT: 1064 cc ENGINE FAMILY: 7MGXCI.06LSC THIS VEHICLE CONFORMS TO U.S. EPA AND CALIFORNIA REGULATIONS APPLICABLE TO 2007 MODEL YEAR NEW MOTORCYCLES AND IS CERTIFIED TO 0.8 HC-NOX G/KM ENGINE FAMILY EXHAUST EMISSION STANDARD. ENGINE EXHAUST CONTROL SYSTEM: HO2S - TWC - SFI</p> <p>ENGINE TUNE UP SPECIFICATIONS IGNITION TIMING: 18° ± 2° AT 3250 RPM IDLE SPEED: 1100 ± 100 RPM IN NEUTRAL VALVE CLEARANCE: INLET 0.0039 inch (0.10 mm) OUTLET 0.0059 inch (0.15 mm)</p> <p>SPARK PLUG: NGK PMR8B, NGK BPR6ES FUEL: MINIMUM OCTANE RATING (M+R)2 METHOD 90 OIL: ENGINE OIL VISCOSITY SAE 10W/60</p> <p>MOTO GUZZI S.p.A. Via E. Parodi, 57 23826 Mandello del Lario (LC) ITALY</p> <p style="text-align: right;"></p> </div>
12	Muffler stamping.

PART 575.6, CONSUMER INFORMATION

Piaggio Group Americas, Inc.
140 East 45th Street, 17th Floor New York, NY 10017 U.S.A.

Reporting Safety Defects

If you believe that your vehicle has a defect which could cause a crash or could cause injury or death, you should immediately inform the National Highway Traffic Safety Administration (NHTSA) in addition to notifying **Piaggio Group Americas, Inc.**

If NHTSA receives similar complaints, it may open an investigation, and if it finds that a safety defect exists in a group of vehicles, it may order a recall and remedy campaign. However, NHTSA cannot become involved in any individual problems between you, your dealer, or **Piaggio Group Americas, Inc.**

To contact NHTSA you may either call the Auto Safety Hotline toll-free at 1-888-327-4236 or write to:

NHTSA
U.S. DEPARTMENT of TRANSPORTATION
400 7th Street SW, (NVS-223) Washington, DC 20590

You can also obtain other information about motor vehicle safety from the Hotline.

EVAPORATIVE EMISSION SYSTEM

The system consists of:

- 1) Carbon filter
- 2) Support plate
- 3) Phillips screw, SWP
- 4) Hose clamp
- 5) Hose clamp
- 6) Fuel pipe
- 7) Pressure valve
- 8) Pipe
- 9) 3-way union
- 10) Bored screw
- 11) 2-way union
- 12) Union
- 13) O-ring
- 14) O-ring
- 15) Union

NOTE In the event of a fuel system malfunction, contact your Local **Moto Guzzi Dealer**

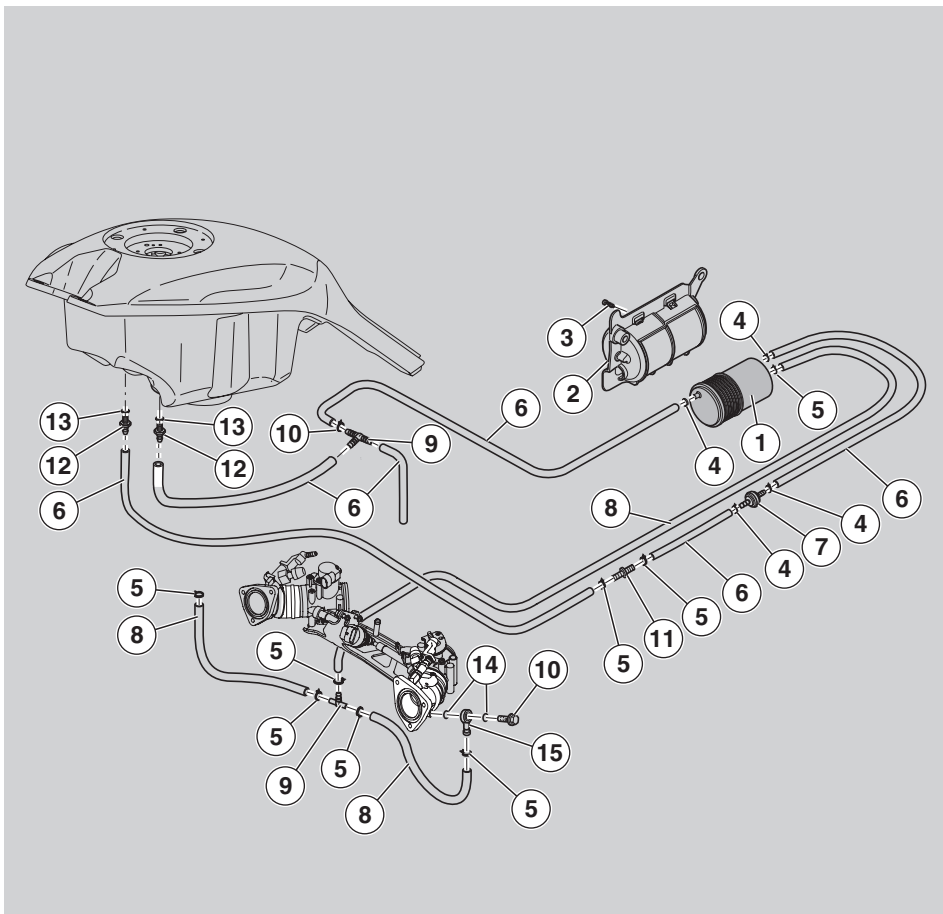

Moto Guzzi S.p.A. - EMISSION CONTROL SYSTEM WARRANTY STATEMENT

YOUR WARRANTY RIGHTS AND OBLIGATIONS

The California Air Resources Board and **Moto Guzzi S.p.A.** (hereinafter "**Moto Guzzi**") are pleased to explain the emission control system warranty on your 1999 and later motorcycle. In California, new motor vehicles must be designed, built and equipped to meet the State's stringent anti-smog standards. **Moto Guzzi** must warrant the emission control system on your motorcycle for the periods of time listed below provided there has been no abuse, neglect or improper maintenance of your motorcycle.

Your emission control system may include parts such as the carburetor or fuel injection system, ignition system, catalytic converter and engine computer. Also included may be hoses, belts, connectors and other emission-related assemblies.

Where a warrantable condition exists, **Moto Guzzi** will repair your motorcycle at no cost to you, including diagnosis, parts and labor.



MANUFACTURER'S EMISSIONS SYSTEM WARRANTY COVERAGE

Class I motorcycles (50 - 169 cm³): for a period of use of five (5) years or 7,456 miles (12,000 kilometers), whichever comes first.

Class II motorcycles (170 - 279 cm³): for a period of use of five (5) years or 11,185 miles (18,000 kilometers), whichever comes first.

Class III motorcycles (280 cm³ and larger): for a period of use of five (5) years or 18,641 miles (30,000 kilometers), whichever comes first.

If an emission-related part on your motorcycle is defective, the part will be repaired or replaced by **Moto Guzzi**. This is your emission control system DEFECTS WARRANTY.

OWNER'S WARRANTY RESPONSIBILITIES

- As the motorcycle owner, you are responsible for the performance of the required maintenance listed in your owner's manual. **Moto Guzzi** recommends that you retain all receipts covering maintenance on your motorcycle, but **Moto Guzzi** cannot deny warranty solely for the lack of receipts or for your failure to ensure the performance of all scheduled maintenance.
- You are responsible for presenting your motorcycle to a **Moto Guzzi** dealer as soon as a problem exists. The warranty repairs should be completed in a reasonable amount of time, not to exceed 30 days.
- As the motorcycle owner, you should be aware that **Moto Guzzi** may deny your warranty coverage if your motorcycle or a part has failed due to abuse, neglect, improper maintenance or unapproved modifications.

If you have any questions regarding your warranty rights and responsibilities, you should contact

Moto Guzzi USA

140 East 45th Street, 17th Floor
New York, NY 10017
Tel: 877.277.4552 (877.Aprilia)
Fax: 001.212.380.4459

Moto Guzzi S.p.A. - LIMITED WARRANTY ON EMISSION CONTROL SYSTEM

Moto Guzzi S.p.A., Via E. V. Parodi, 57 23826 Mandello del Lario (LECCO) Italy (hereinafter "**Moto Guzzi**") guarantees that each new 1999 and later **Moto Guzzi** motorcycle, which includes as standard equipment a headlight, taillight and stoplight, and is street legal:

- A) is designed, built and equipped so as to conform at the time of first retail purchase with all applicable regulations of the United States Environmental Protection Agency, and the California Air Resources Board; and
- B) is free from defects in materials and workmanship which may deny the motorcycle compliance with applicable regulations of the United States Environmental Protection Agency or the California Air Resources Board for a period of use, depending on the engine displacement, of 7,456 miles (12,000 km), if the motorcycle's engine displacement is less than 170 cubic cm; of 11,185 miles (18,000 km), if the motorcycle's engine displacement is equal to or greater than 170 cubic cm but less than 280 cubic cm; or of 8,641 miles (30,000 km), if the motorcycle's engine displacement is 280 cubic cm or greater; or 5 (five) years from the date of first retail delivery, whichever comes first.

- I. **COVERAGE.** Warranty defects shall be remedied during regular business hours at any authorized **Moto Guzzi** motorcycle dealer located within the United States of America in compliance with the Clean Air Act and applicable regulations of the United States Environmental Protection Agency and the California Air Resources Board. Any part or parts replaced under this warranty shall become the property of **Moto Guzzi**.

State of California only: emission-related warranted parts are specifically defined by the state's Emission Warranty Parts List. These warranted parts are: carburetor and internal parts; intake manifold; fuel tank; fuel injection system; spark advance mechanism; crankcase breather; air cutoff valves; fuel tank cap for evaporative emission controlled vehicles; oil filler cap; pressure control valve; fuel/vapor separator; canister; igniters; breaker governors; ignition coils; ignition wires; ignition points; condensers, and spark plugs if failure occurs prior to the first scheduled replacement; and hoses, clamps, fittings and tubing used directly in these parts. Since emission related parts may vary from model to model, certain models may not contain all of these parts and certain models may contain functionally equivalent parts.

State of California only: Emission Control System emergency repairs, as provided for in the California Administrative Code,

may be performed by other than an authorized **Moto Guzzi** dealer. An emergency situation occurs when an authorized **Moto Guzzi** dealer is not reasonably available, a part is not available within 30 days, or a repair is not complete within 30 days. Any replacement part can be used in an emergency repair. **Moto Guzzi** will reimburse the owner for the expenses, including diagnosis, not to exceed **Moto Guzzi's** suggested retail price for all warranted parts replaced and labor charges based on **Moto Guzzi's** recommended time allowance for the warranty repair and the geographically appropriate hourly labor rate. The owner may be required to keep receipts and failed parts in order to receive compensation.

- II. **LIMITATIONS.** This Emission Control System warranty shall not cover any of the following:
 - A) Repair or replacement required as a result of
 - (1) accident,
 - (2) misuse,
 - (3) repairs improperly performed or replacements improperly installed,
 - (4) use of replacement parts or accessories not complying with **Moto Guzzi** specifications that adversely affect performance, and/or
 - (5) use in competitive racing or related events.

- B) Inspections, replacement of parts and other services and adjustments required for required maintenance.
- C) Any motorcycle on which the odometer mileage has been changed so that actual mileage cannot be readily determined.

III. LIMITED LIABILITY

A) The liability of **Moto Guzzi** under this Emission Control System Warranty is limited solely to the remedying of defects in material or workmanship by an authorized **Moto Guzzi** motorcycle dealer at its place of business during customary business hours. This warranty does not cover inconvenience or loss of use of the motorcycle or transportation of the motorcycle to or from the **Moto Guzzi** dealer. **Moto Guzzi** SHALL NOT BE LIABLE FOR ANY OTHER EXPENSES, LOSS OR DAMAGE, WHETHER DIRECT, INCIDENTAL, CONSEQUENTIAL OR EXEMPLARY IN CONNECTION WITH THE SALE OR USE OF, OR INABILITY TO USE, THE **Moto Guzzi** MOTORCYCLE FOR ANY PURPOSE. SOME STATES DO NOT ALLOW THE EXCLUSION OR LIMITATION OF ANY INCIDENTAL OR CONSEQUENTIAL DAMAGES, SO THE ABOVE LIMITATIONS MAY NOT APPLY TO YOU.

B) NO EXPRESS EMISSION CONTROL SYSTEM WARRANTY IS GIVEN BY **Moto Guzzi** EXCEPT AS SPECIFICALLY SET FORTH HEREIN. ANY EMISSION CONTROL SYSTEM WARRANTY IMPLIED BY LAW, INCLUDING ANY WARRANTY OF MERCHANTABILITY OR FITNESS FOR A PARTICULAR PURPOSE, IS LIMITED TO THE EXPRESS EMISSION CONTROL SYSTEM WARRANTY TERMS STATED IN THIS WARRANTY. THE FOREGOING STATEMENTS OF WARRANTY ARE EXCLUSIVE AND IN LIEU OF ALL OTHER REMEDIES. SOME STATES DO NOT ALLOW LIMITATIONS ON HOW LONG AN IMPLIED WARRANTY LASTS, SO THE ABOVE LIMITATIONS MAY NOT APPLY TO YOU.

C) No dealer is authorized to modify this **Moto Guzzi** Limited Emission Control System Warranty.

IV. **LEGAL RIGHTS.** THIS WARRANTY GIVES YOU SPECIFIC LEGAL RIGHTS. YOU MAY ALSO HAVE OTHER RIGHTS WHICH VARY FROM STATE TO STATE.

V. THIS WARRANTY IS IN ADDITION TO THE **Moto Guzzi** LIMITED MOTORCYCLE WARRANTY.

VI. **ADDITIONAL INFORMATION.** Any replacement part that is equivalent in performance and durability may be used in the performance of any maintenance or repairs. However, **Moto Guzzi** is not liable for these parts. The owner is responsible for the performance of all required maintenance. Such maintenance may be performed at a service establishment or by any individual. The warranty period begins on the date the motorcycle is delivered to an end purchaser.

Moto Guzzi

Via E. V. Parodi, 57
23826 Mandello del Lario (LECCO) Italy

Moto Guzzi USA

140 East 45th Street, 17th Floor
New York, NY 10017
U.S.A.

GENERAL INSTRUCTIONS

★ The operations preceded by this symbol must also be repeated on the opposite side of the vehicle.

Unless expressly indicated otherwise, to reassemble the units repeat the disassembly operations in reverse order.

The terms "right" and "left" refer to the rider seated on the vehicle in the normal riding position.

These data indicate:

- year of manufacture (Y, 1, 2, ...);
- modification code (A, B, C, ...);
- country of homologation (I, UK, A, ...).

and are to be supplied to the Local **Moto Guzzi** Dealer as reference data for the purchase of spare parts or specific accessories of the model you have acquired.

In this manual the various versions are indicated by the following symbols:

OPT optional

VERSION:

I Italy	SGP Singapore
UK United Kingdom	SLO Slovenia
A Austria	IL Israel
P Portugal	ROK South Korea
SF Finland	MAL Malaysia
B Belgium	RCH Chile
D Germany	HR Croatia
F France	AUS Australia
E Spain	USA United States of America
GR Greece	BR Brazil
NL Holland	RSA South Africa
CH Switzerland	NZ New Zealand
DK Denmark	CDN Canada
J Japan	

GENERAL INDEX

FOREWORD	2
INTRODUCTION	2
SAFETY WARNINGS	3
GENERAL SAFETY RULES	3
CARBON MONOXIDE.....	3
HOT COMPONENTS.....	4
USED ENGINE OIL.....	4
BRAKE FLUID.....	4
CLUTCH FLUID.....	4
COOLANT.....	5
BATTERY HYDROGEN GAS AND ELECTROLYTE.....	5
WARNINGS - PRECAUTIONS - GENERAL ADVICE	5
REPORTING DEFECTS THAT AFFECT SAFETY ROAD REGULATIONS AND USING THE VEHICLE.....	6
NOISE EMISSION WARRANTY.....	6
INFORMATION ON THE NOISE AND EXHAUST GAS EMISSION CONTROL SYSTEM.....	6
TAMPERING WARNING.....	6
VEHICLE IDENTIFICATION NUMBER (V.I.N.) (FRAME NUMBER).....	7
INFORMATION CONTAINED IN THE VEHICLE IDENTIFICATION NUMBER.....	7
DIGIT MEANING.....	8
POSITION OF THE WARNING ADHESIVE LABELS.....	9
WARNING ADHESIVE LABELS CHART.....	10
EVAPORATIVE EMISSION SYSTEM.....	12
MOTO GUZZI S.P.A. - EMISSION CONTROL SYSTEM WARRANTY STATEMENT.....	13
MOTO GUZZI S.P.A. - LIMITED WARRANTY ON EMISSION CONTROL SYSTEM.....	14
GENERAL INSTRUCTIONS	16
GENERAL INDEX.....	17
BASIC SAFETY RULES.....	20
CLOTHING.....	25
ACCESSORIES.....	26
LOAD.....	26
POSITION OF KEY COMPONENTS	28
LOCATION OF INSTRUMENTS/CONTROLS	30

INSTRUMENTS AND INDICATORS	30
INSTRUMENTS AND INDICATORS TABLE.....	31
MULTIFUNCTION COMPUTER.....	33
CONTROLS.....	33
TRIP 1 AND 2.....	33
MODE.....	34
LAP TIME.....	34
MENU.....	35
SERVICE INTERVAL.....	38
ALARM DISPLAY.....	38
MAIN INDEPENDENT CONTROLS	39
CONTROLS ON LEFT HANDLEBAR.....	39
CONTROLS ON RIGHT HANDLEBAR.....	40
IGNITION SWITCH.....	41
STEERING LOCK.....	41
PARKING LIGHTS.....	42
AUXILIARY EQUIPMENT	43
UNLOCKING/LOCKING THE SEAT.....	43
TOOL KIT COMPARTMENT.....	43
LUGGAGE ANCHOR POINTS.....	44
ACCESSORIES.....	45
MAIN COMPONENTS	46
FUEL.....	46
LUBRICANTS.....	47
BRAKES.....	48
DISK BRAKES.....	49
FRONT BRAKE.....	50
REAR BRAKE.....	51
TOPPING UP.....	52
CLUTCH FLUID - RECOMMENDATIONS.....	52
CLUTCH.....	53
TIRES.....	55
ENGINE OIL.....	56
ADJUSTING THE FRONT BRAKE LEVER AND THE CLUTCH LEVER.....	57
CATALYTIC SILENCER.....	58
EXHAUST MUFFLER/EXHAUST SILENCER.....	58
INSTRUCTIONS FOR USE	59
GETTING ON AND OFF THE VEHICLE.....	59
PRE-RIDE CHECKS.....	61
PRE-RIDE CHECKS CHART.....	62
STARTING.....	63
MOVING OFF AND RIDING.....	65

RUNNING-IN.....	68
STOPPING.....	69
PARKING.....	69
PUTTING THE VEHICLE ON THE STAND.....	70
SUGGESTIONS TO PREVENT THEFT.....	71
MAINTENANCE	71
SCHEDULED MAINTENANCE CHART.....	72
IDENTIFICATION DATA.....	75
JOINTS WITH SCREW CLAMPS.....	75
CHECKING AND TOPPING UP ENGINE OIL LEVEL.....	76
FRONT WHEEL.....	77
REAR WHEEL.....	78
FRONT BRAKE CALIPER.....	78
CHECKING THE CARDAN SHAFT OIL LEVEL.....	80
CHECKING GEARBOX FLUID LEVEL.....	80
REARVIEW MIRRORS.....	80
INSPECTING THE FRONT AND REAR SUSPENSIONS.....	81
FRONT SUSPENSION.....	82
REAR SUSPENSION.....	82
CHECKING THE BRAKE PADS FOR WEAR.....	84
ADJUSTING THE THROTTLE CONTROL.....	85
SPARK PLUGS.....	86
CHECKING THE STAND.....	88
BATTERY.....	89
LONG INACTIVITY OF THE BATTERY.....	89
CHECKING AND CLEANING THE TERMINALS.....	89
REMOVING THE BATTERY.....	90
CHECKING BATTERY FLUID LEVEL.....	91
CHARGING THE BATTERY.....	91
INSTALLING THE BATTERY.....	92
CHECKING THE SWITCHES.....	92
CHANGING THE FUSES.....	93
BEAM SETTING.....	95
BULBS.....	96
CHANGING THE HEADLIGHT BULBS.....	97
CHANGING THE FRONT AND REAR TURN INDICATOR BULBS.....	98
CHANGING THE TAIL LIGHT BULB.....	98
REPLACING THE NUMBER PLATE BULB.....	98
TRANSPORT	99
DRAINING THE FUEL TANK.....	99

CLEANING	100
LONG PERIODS OF INACTIVITY	101
TECHNICAL DATA	103
LUBRICANT CHART.....	106
AUTHORIZED DEALERS AND SERVICE CENTERS	108



SAFE DRIVE

BASIC SAFETY RULES

The instructions given below cover normal operation of your vehicle and must be carefully observed. Following these rules will increase your own safety and the safety of those around you. You will also maximize the life and utility of your vehicle.

Two-wheeled vehicles obviously do not provide some of the protection provided by automobiles, therefore it is essential that you wear appropriate protective clothing. Never operate your vehicle without wearing your helmet, gloves, eye protection, a heavy jacket, sturdy footwear, and sturdy full length pants.

However, do not assume that even the best clothing and helmet will protect you in the event of an accident or a crash with another vehicle. At best, this gear provides some protection from scrapes and scratches, but very little, if any, impact protection.

Be sure that you meet all the requirements prescribed by local law, including driver's license, minimum age, training, insurance, taxes, vehicle registration, license plate, etc.

When you first receive your vehicle, practice by riding in areas where there is little traffic. Do not attempt to ride in heavy traffic until you are thoroughly experienced and until riding your vehicle has become second nature to you.



Although this vehicle is legal for operation on freeways and expressways, it is not advisable to ride in high-speed traffic until you are thoroughly familiar with your vehicle, and have attained a high degree of skill in its operation.

A new vehicle must be carefully broken in, see 68 (RUNNING-IN).

Before starting the engine, make sure that the brakes, clutch, transmission and throttle controls function properly and that the fuel and oil supply is adequate.

The exhaust system, brakes, and some other parts of the vehicle become very hot during operation. Do not touch any of these parts.

Some medicines or drugs, illegal or prescription, and alcohol significantly increase the risk of accident. Do not ride while you are under the influence of alcohol or drugs, illicit or prescription. Make sure you are in good physical condition



and not ill before riding your vehicle. Do not ride your vehicle when you are particularly tired or fatigued. Alcohol, drugs and fatigue are leading causes of vehicle accidents.

Many accidents are caused by the rider's inexperience and lack of training. Do not ride your vehicle until you have received training from a recognized training organization such as the Motorcycle Safety Foundation. Remember that riding a two-wheeled vehicle, though easy and fun, is quite different from driving a car. Do not assume that you can operate your vehicle safely just because you are a competent automobile driver.

Never lend your vehicle to others unless you are sure that they are competent and properly licensed vehicle operators.



Observe all traffic regulations. Pay special attention to all warning, regulatory and informational signs.

Avoid showing off (popping wheelies, etc.). Especially observe speed limits; remember that road conditions change with the weather and wet and icy pavements are particularly dangerous for vehicles, especially if you are riding too fast. Remember that automobile drivers have a hard time seeing two wheeled vehicles, so always give the automobile the right of way, even if it is legally yours.

Before changing lanes, look over your shoulder to make sure that the way is clear. Do not rely exclusively on the rearview mirror: you may miscalculate the distance and speed of a vehicle, or you may not even see it at all.

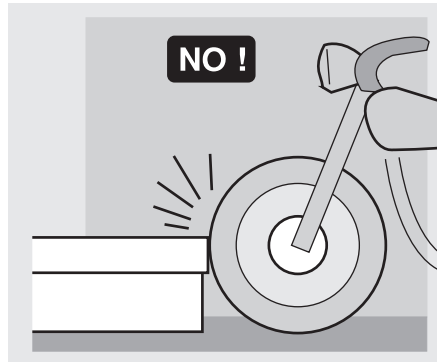

Avoid obstacles that could damage the vehicle or make you lose control.

Do not tailgate. Do not attempt to increase your gas mileage by following in the slip stream of cars or trucks in front of you.

In case of accident, motorcycles, scooters and mopeds do not provide the same degree of protection as automobiles. Legs, in particular, are exposed to injury. However, the additional installation of leg guards may actually increase the risk of injury and their seriousness in case of accident.

Do not install leg guards available on the market as spare parts and accessories. Failure to comply with these instructions may result in serious injury or even death.

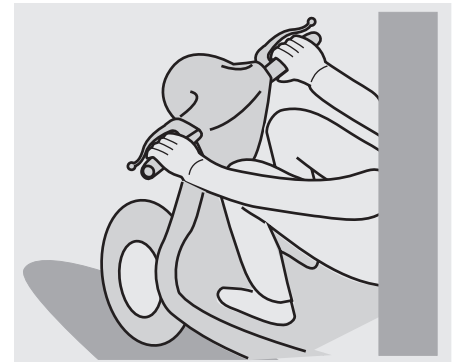

Always ride with both hands on the handlebars and feet on the footrests.

Never shift gear without using the clutch, if the vehicle is equipped with one. Do not operate the shift lever or other controls abruptly. Such misuse can damage the internal components of the vehicle and cause seizure, loss of control, accidents and serious injury or even death.

Remain in the seat when you are riding. Do not stand up or attempt to stretch while you are riding your vehicle. If you need to rest, pull over to the side of the road when it can be safely done.

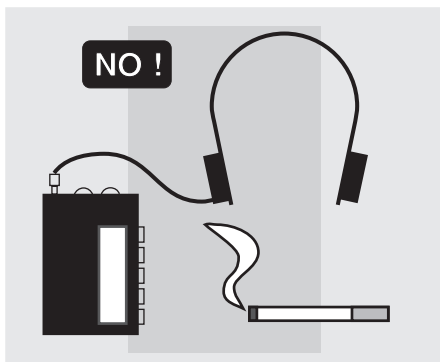

It is very important to your safety that you are fully concentrated on riding. Watch what you are doing, do not allow yourself to be distracted by other cars, people or things on the roadside, etc. Never smoke, eat, drink, read, etc. while riding your vehicle. If you must consult a map, pull over when it can be safely done.

Use only the specific fuels and lubricants for the vehicle indicated in the "LUBRICANT CHART"; check the oil, fuel and coolant levels regularly.

If the throttle sticks open, it may cause a collision with another vehicle, or an accident.

If the throttle sticks, kill the engine with the engine stop switch located on the right handlebar.

Do not attempt to restart the engine until the throttle has been repaired and works perfectly. Failure to obey this warning can lead to a runaway resulting in serious injury



or even death.

Your vehicle is equipped with a double cable throttle. One cable opens the throttle when you rotate the throttle grip toward you; the other closes the throttle when you rotate the grip away from you. It is essential when you release the throttle grip that it goes back automatically to the idle position.

This double cable arrangement increases safety by providing for positive closing of the throttle.

In the event of a throttle sticking emergency, always kill the engine using the engine stop switch located near the throttle grip on the right handlebar. Never use your vehicle if the throttle does not automatically go back all the way to the idle position when the throttle grip is released.

Contact your Local Moto Guzzi Dealer

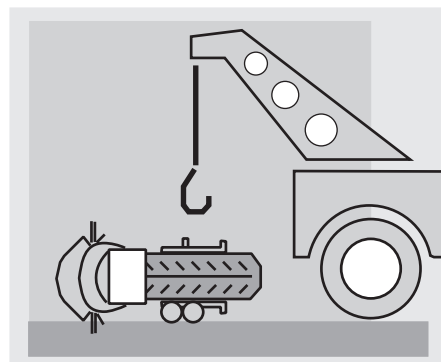

for repairs. Failure to heed this warning can lead to a serious accident and subsequent injury or even death.

If you and your vehicle are involved in an accident, make sure there has been no damage to the control levers, tubes, wires, braking system and other vital parts. If your vehicle is involved in an accident, take it immediately to your Local **Moto Guzzi Dealer**. He has the equipment and knowledge to check for accidental damage which may compromise your safety.

Your **Moto Guzzi dealer** is ready and able to help you with any safety problems you might have, but you must necessarily report any malfunctions to your mechanic in order for him to help you.

Do not use your vehicle if it is damaged. A damaged vehicle may become unstable or present other problems which can increase the risk of accident, and therefore of serious injury or even death.

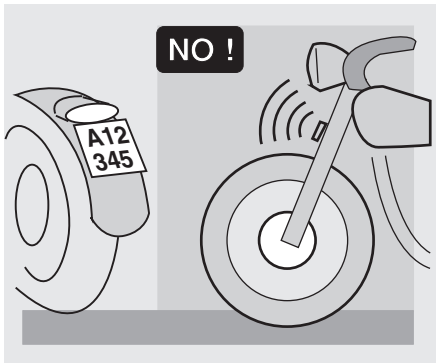

Do not attempt to modify the position, angle or color of your license plate. Do not cover it even with a clear plastic covering. Do not modify any of the safety equipment of your vehicle, especially safety related items such as turn indicators, rear view mirrors, lights or horns.

Any modification to your vehicle will invalidate the warranty.

Do not modify your engine in an attempt to increase the horsepower. This can result in irreparable damage to the engine, as well as degradation of the performance and handling of the vehicle which could lead to an accident, and serious injury or even death.

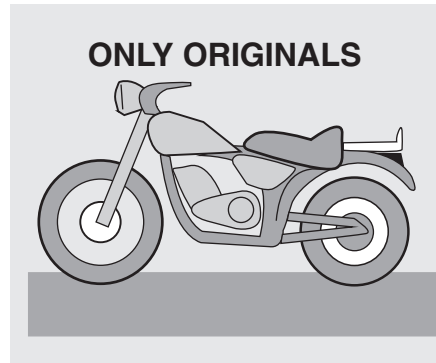

Have your vehicle repaired only with original parts, and use only original **Moto Guzzi** or **Moto Guzzi** authorized accessories. The use of aftermarket accessories and parts can seriously compromise the safety of your vehicle, its performance and serviceability. Any modification that affects performance or safety voids your warranty completely.

Tampering with the emissions or noise control systems on your vehicle is against the law, and can be punished by large fines.

In some jurisdictions, it can even lead to the confiscation of your vehicle.

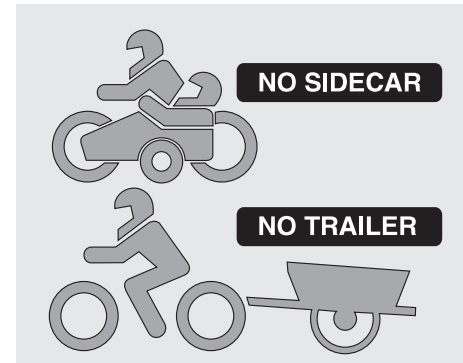

This vehicle was not designed to be equipped with a sidecar or be used to tow trailers or other vehicles.

Moto Guzzi does not manufacture sidecars or trailers and therefore cannot predict the effects of such accessories on the maneuverability or stability of the vehicle: it can only warn that such effects may be negative and that any damage to the vehicle components caused by the use of such accessories will not be covered by the warranty.

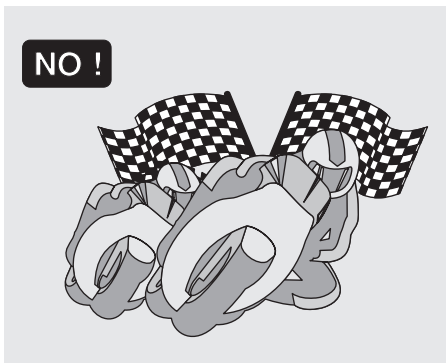

Never race other vehicles with your vehicle.

Brake with both the front and rear brakes. The use of one brake only for sudden braking may cause the vehicle to skid or make the rider lose control of the vehicle itself.

When riding down a steep hill, use the engine as a brake by selecting the same gear, or a lower gear, than you would use to climb the hill. Use front and rear brakes sparingly.

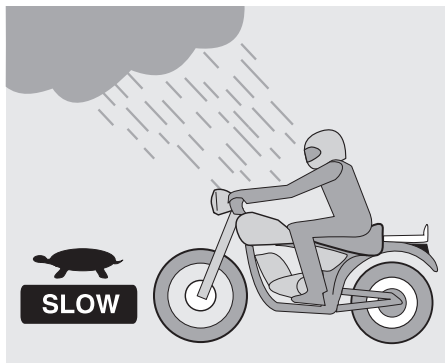

Always ride at the appropriate speed and avoid unnecessary hard acceleration. This is not only safer, but also reduces fuel consumption and extends the life of the vehicle.

If you must ride your vehicle in rainy weather or on loose surfaces, remember that traction is greatly reduced. Under these conditions, the vehicle must always be handled gradually and smoothly. Sudden acceleration, braking or turning may make you lose control of your vehicle. When traction is reduced, accelerate and slow using your vehicle's engine braking insofar as possible. Avoid hard or abrupt braking.

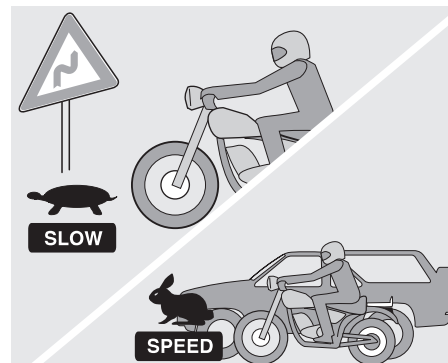

Open and close the throttle gradually to prevent the rear wheel from spinning or skidding.

On rough road surfaces, slow down and use care.

Try to avoid wide open throttle accelerations, unless they are necessary for such things as passing.

Don't allow your engine to "lug," that is, run at too low an rpm. Shift to a lower gear. Also, don't over-rev the engine. Observe the redline on the tachometer.

Remember that aggressive cornering can cause your vehicle's tires to lose lateral traction, which can result in an accident and serious injury or even death.



Always observe posted and statutory speed limits, but do not assume that you can ride as fast as the speed limit under all road conditions. Slowing down a little can greatly increase your safety under all road conditions.

Do not ride your vehicle off road.

Do not tamper with the muffler system or the emissions control system of your vehicle. This is not only bad for the environment, it can subject you to serious fines.

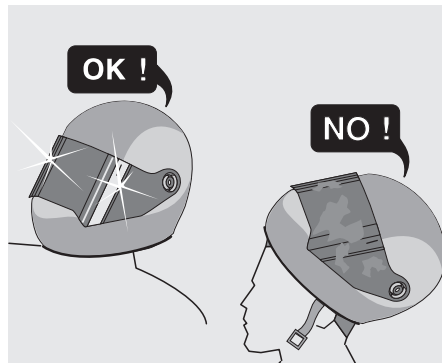

CLOTHING

Before riding your vehicle, ensure that your riding gear is in good condition. To be effective, your helmet must fit properly, and the visor or other eye protection must be clean.

Both research and experience have shown that drivers of other vehicles often do not see vehicles or riders. In order to make yourself more conspicuous to these drivers, wear bright reflective clothing, such as a reflective vest, or clothing with reflective sections sewn into the jacket, pants and gloves. Be particularly aware of approaching automobiles and trucks that might be trying to turn left in front of you. Many vehicle accidents are caused by an opposing automobile driver making a left turn without warning in front of the vehicle.

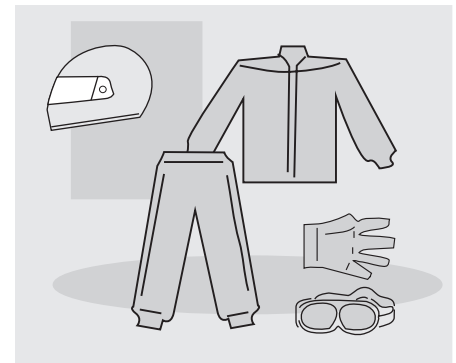

Inevitably, the driver will look right at you, and yet swear that they did not see you before they turned directly into your path. Ride alert!

Wear protective clothing, preferably in light and/or reflecting colors. In this way you will make yourself more visible to the other drivers, thus notably reducing the risk of being knocked down, and you will be more protected in case of fall.

Always wear your crash helmet. Many accidents are fatal because of injuries to the head.

This clothing should be very tight-fitting and fastened at the wrists and ankles. Strings, belts and ties should not be hanging loose; prevent these and other objects from interfering with driving by getting entangled with moving parts or driving mechanisms.

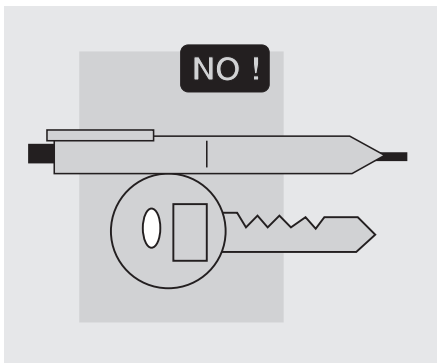

Do not carry sharp objects in your pockets that could be dangerous in case of an accident, for example, pens or mechanical pencils, etc. Also, make sure that your passengers follow this recommendation.

ACCESSORIES

The owner of the vehicle is responsible for the choice, installation and use of any accessory.

Installing inappropriate accessories or overloading the vehicle may result in the instability of the vehicle itself and cause accidents, with consequent risk of serious injuries or even death. Windshields can be especially dangerous, as they can break and injure or cut the rider in case of accident. If you have any doubts about an accessory you would like to install or a load you would like to carry, first consult your Local **Moto Guzzi** Dealer.

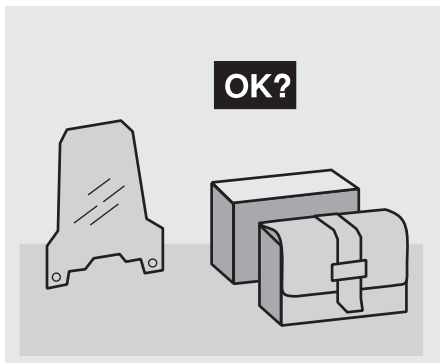

Avoid installing accessories that cover horns or lights or that could impair their function, limit the suspension stroke and steering angle, hamper operation of the controls and reduce the distance from the ground and the angle of inclination in turns.

Avoid using accessories that hamper access to controls, since this can prolong reaction times during an emergency.

Fairings and windshields installed on the vehicle may produce aerodynamic forces that will affect the stability of the vehicle during use, especially at high speeds.

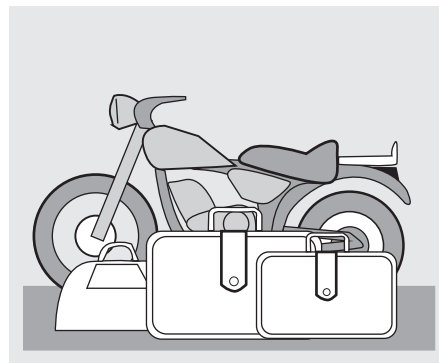

Make sure that anything you carry on your vehicle is securely fastened and cannot come loose, jam the wheels, forks, etc. Do not install any electrical accessories, and do not modify the electrical system of your vehicle. Anything that can cause an electrical overload or other fault can cause the vehicle to stop suddenly, the lights to dim or go out, or the horn and other safety accessories to cease functioning. Use only genuine **Moto Guzzi** accessories.

LOAD

Do not overload your vehicle. Fasten luggage or packages as close as possible to the center of your vehicle and distribute the load from side to side as evenly as possible to keep imbalance to a minimum. Remember that loads tend to loosen during riding, so often that your load is secure.

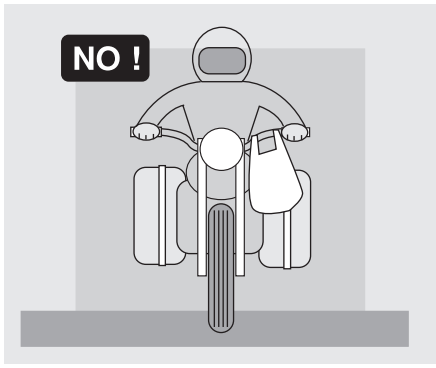

Do not hang anything from your vehicle handlebars, fenders, or forks, because this will affect handling and prevent you from avoiding an accident. Failure to heed this warning can lead to an accident with subsequent serious injury or even death.

Do not ride with your crash helmet hanging from its strap because it can become caught in the wheels, fenders, or forks, causing an accident and subsequent serious injury or even death.

Carry a passenger only if your vehicle is equipped with passenger footrests, handgrips for the passenger to hold on to, and a passenger saddle.

When carrying a passenger, remember that your vehicle's handling is reduced, that the brakes are less efficient, and the center of gravity is higher and further to the rear.

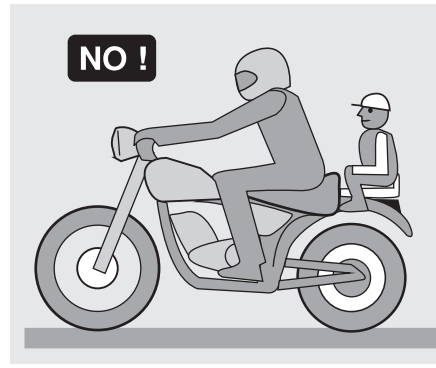

This makes it more likely that the front wheel will raise off the ground, especially on acceleration. Therefore, you should avoid hard acceleration and hard braking. Many accidents are caused by inexperienced riders carrying passengers. Remember that allowance must be made for the extra weight of the passenger for all driving maneuvers.

Avoid abrupt and excessive acceleration. Always slow down in time and calculate longer stopping and maneuvering distances. Failure to comply with these instructions may lead to the vehicle overturning or to other accidents, with serious injury or even death being the consequence.

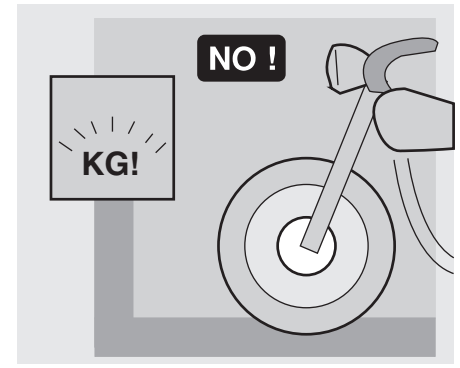

Never carry loosely packaged items; make sure that everything you carry on your vehicle is carefully secured.

Do not carry packages that protrude from the luggage rack or that cover any of the signal lights, the headlight or the horn.

Never carry animals or children on the glove compartment or luggage rack.

Never exceed the labeled maximum load for each saddlebag.

Overloading your vehicle seriously reduces its stability and maneuverability and can lead to an accident with subsequent serious injury or death.

POSITION OF KEY COMPONENTS

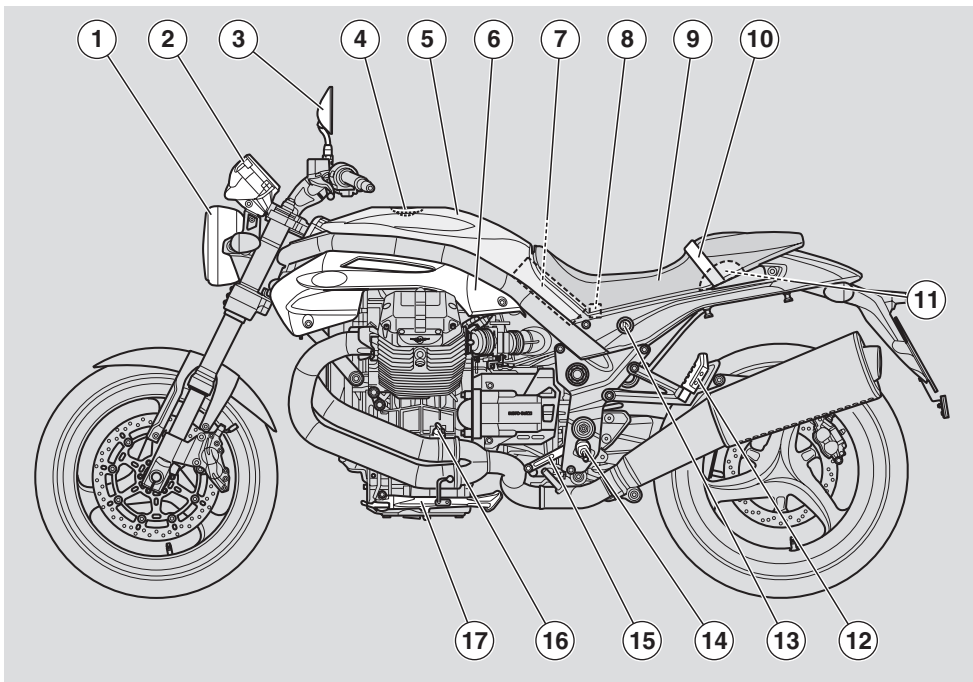

KEY

- | | | |
|-------------------------|----------------------------|-------------------------|
| 1) Headlight | 8) Main fuse carrier (30A) | 15) Gear shift lever |
| 2) Instrument panel | 9) Passenger/rider seat | 16) Engine oil dipstick |
| 3) Left rearview mirror | 10) Passenger grab strap | 17) Side stand |
| 4) Fuel tank filler cap | 11) Tool kit compartment | |
| 5) Fuel tank | 12) Left passenger footpeg | |
| 6) Left side body panel | 13) Seat lock | |
| 7) Battery | 14) Rider left footrest | |

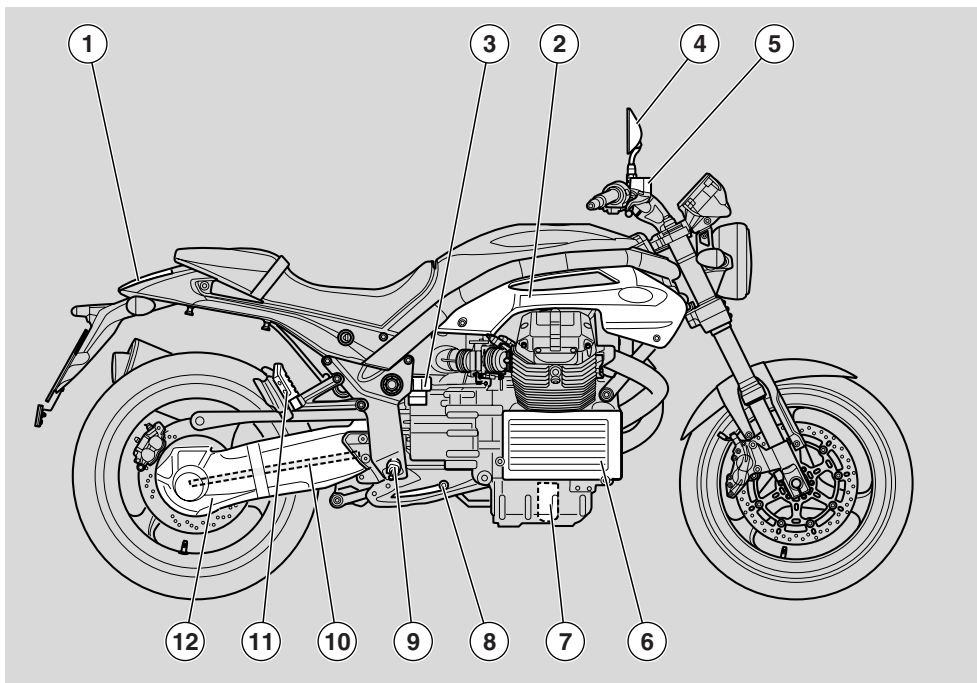

KEY

- | | |
|---|-------------------------------|
| 1) Tail light | 8) Rear brake control lever |
| 2) Right side body panel | 9) Right rider footrest |
| 3) Rear brake fluid reservoir | 10) Cardan shaft |
| 4) Right rearview mirror | 11) Right passenger footpeg |
| 5) Front brake fluid reservoir | 12) Single-sided swinging arm |
| 6) Oil cooler  | |
| 7) Engine oil filter | |

LOCATION OF INSTRUMENTS/CONTROLS

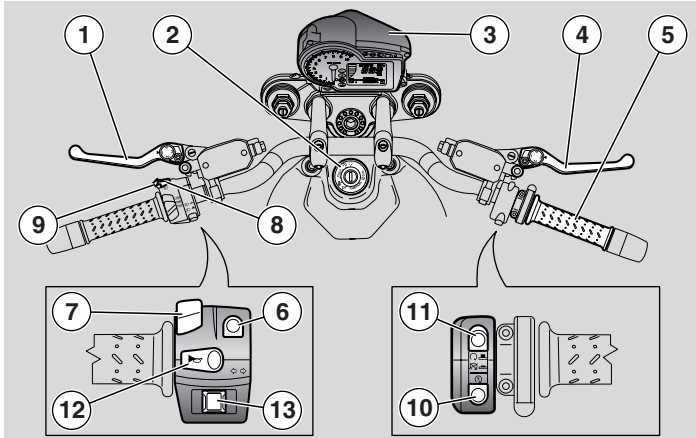

LOCATION OF INSTRUMENTS/CONTROLS - KEY

- 1) Clutch lever
- 2) Ignition switch/steering lock (⊙-⊗-P-ε)
- 3) Instruments and indicators
- 4) Front brake lever
- 5) Throttle grip
- 6) Dimmer switch (⊞-⊟)
- 7) Display functions switch
- 8) High beam flasher - passing button
- 9) SET pushbutton
- 10) Starter button (⊞)
- 11) Engine stop switch (⊙-⊗)
- 12) Horn button (⊞)
- 13) Turn indicator switch (↔)

INSTRUMENTS AND INDICATORS

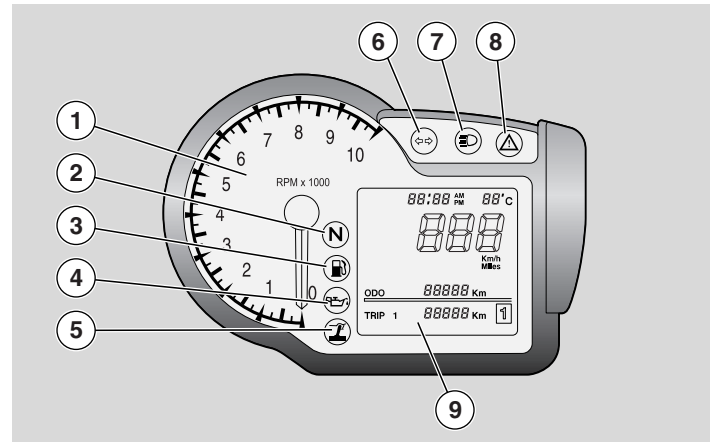



LOCATION OF INSTRUMENTS/CONTROLS - KEY











- 1) Revolution counter
- 2) Green neutral light (N)
- 3) Orange low fuel warning light (⊞)
- 4) Red engine oil pressure warning light (⊞)
- 5) Yellow side stand light (⊞)
- 6) Green turn indicator warning light (↔)
- 7) Blue high beam warning light (⊞)
- 8) Red alarms/immobilizer warning light (⊞)
- 9) Multifunction digital display.

INSTRUMENTS AND INDICATORS TABLE

When the ignition key is turned to "⊙" with the engine stopped, all warning lights come on for a LED check-up and go out after three seconds. If one or more warning lights do not come on at this stage, contact a **Moto Guzzi Authorized Dealer**.

Description		Function
Multifunction digital display	Speedometer (km/h - MPH)	Displays current, average or maximum riding speed (in kilometres or miles) depending on presetting, see page 33 (MULTIFUNCTION COMPUTER).
	Odometer (KM - Mi)	Displays partial or total Km/miles run, see page 33 (MULTIFUNCTION COMPUTER).
	Ambient temperature (°C/°F)	Displays ambient temperature, the value is shown in the top right corner of the display. When temperature is close to 3° C (37 °F) the ice symbol should be displayed. Range in °C or °F is selected through the display, see page 33 (MULTIFUNCTION COMPUTER).
	Clock	Displays time (hour and minutes) as preset, see page 33 (MULTIFUNCTION COMPUTER).
	Battery voltage V BATT 	Displays the battery voltage in Volts, see page 33 (MULTIFUNCTION COMPUTER).
	Lap timer	Displays the different lap times, as preset, see page 33 (MULTIFUNCTION COMPUTER).
	Diagnosis	In case a serious failure is detected, one that might jeopardize the vehicle or the rider's safety, the panel will show an icon indicating the failure cause (such as: oil pressure  , maintenance intervals ). ⚠ CAUTION If the wording "⚠ SERVICE" appears during normal engine operation, it means that the ECU or the instrument panel have detected a failure. In most cases, the engine will keep running, although giving less performance. Immediately contact a Moto Guzzi Authorized Dealer .
Revolution counter <i>rpm</i>	Indicates the number of revolutions of the engine per minute. ⚠ CAUTION Never exceed the engine max. speed rate, see page 48 (RUNNING-IN).	

Continued ►

Description	Function
Engine oil pressure warning light 	<p>Comes on when the ignition switch is set to "  " with the engine stopped as a lamp test. If the light does not come on in this phase, contact a Moto Guzzi Authorized Dealer.</p> <p>⚠ CAUTION If the engine oil pressure warning light  remains on after the start or comes on during the normal operation of the engine, this means that the engine oil pressure in the circuit is insufficient. In this case, stop the engine immediately and contact a Moto Guzzi Authorized Dealer.</p>
Alarm led 	<p>Works as general alarm warning (excluded the engine oil pressure one) and gear shift indicator.</p> <p>⚠ CAUTION If the LED "  " stays on after the engine is started or comes on during normal engine operation, it means that the control unit has detected a failure; immediately contact a Moto Guzzi Authorized Dealer.</p> <p>If LED warning light "  " flashes when the vehicle is off it means that immobiliser or optional antitheft alarm have been enabled.</p>
Turn indicator warning light 	Blinks when the direction indicators are on.
High beam warning light 	Comes on when the high beam bulbs are on or when the headlight signaller is operated.
Low fuel warning light 	Comes on when the quantity of fuel left in the tank is approx. 0.87 US gal. (3.3 ℓ). In this case, top up as soon as possible, see page 28 (FUEL).
Neutral indicator warning light 	Comes on when the gear is in neutral.
Side stand down light 	Turns on when the side stand is down.

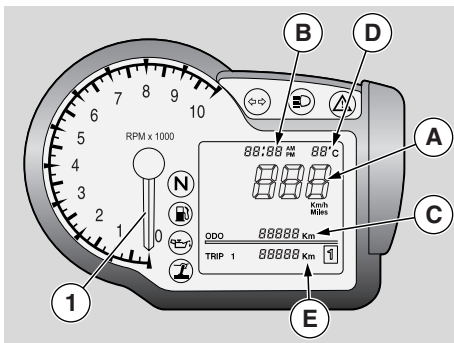

MULTIFUNCTION COMPUTER

When you turn the ignition key to "ON", the following instrument panel lights will turn on for 2 seconds:

- the "GRISO" logo
- all warning lights
- backlighting

Rev counter index (1) moves to maximum value, as set by the user.

After 2 seconds, all instruments will briefly show the current values of the corresponding parameters.

The display shows the following standard settings:

- speed (zone a)
- clock (zone B)
- odometer (zone C)
- ambient temperature (zone D)
- on-board computer and accessories functions (zone E)

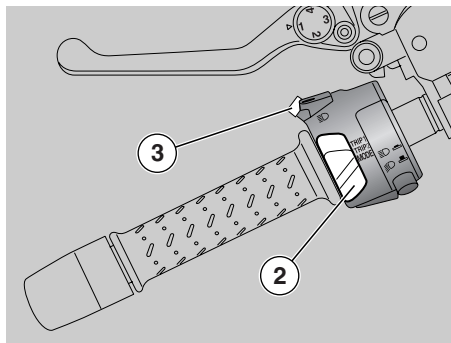

CONTROLS

- 2) Switch with three positions: TRIP1 / TRIP2 / MODE
- 3) SET button; briefly press it to scroll the functions in the menus, press for several seconds to confirm selected option.

TRIP METER	TRIP	326.5 Km / h
TRIP TIME	TIME	32:45
FUEL CONSUMPTION	AVG FUEL	12.6
MAXIMUM SPEED	MAX	126 Km / h
AVERAGE SPEED	AVG SPEED	126 Km / h

TRIP 1 AND 2

In TRIP 1 and 2 the data concerning trip 1 and 2 are shown.

Indication of displayed trip meter is on the right, at the bottom.

Set selector (2) to the position corresponding to TRIP configuration to be displayed (TRIP 1 or TRIP 2).

At the bottom (F) are the following data:

- TRIP METER
- TRIP TIME
- FUEL CONSUMPTION
- MAXIMUM SPEED
- AVERAGE SPEED

Briefly press SET (3) to toggle between these parameters. Press it for several seconds to reset all data from selected TRIP meter.

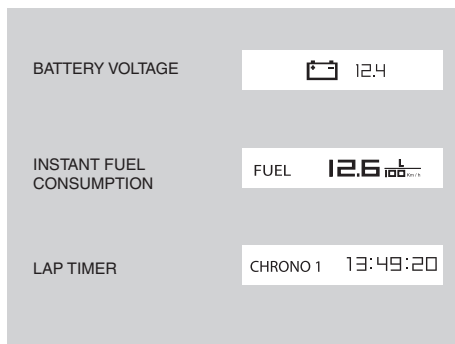

Acquisition ends as soon as 40 lap times are stored; "FULL" is displayed. Stop the vehicle, see page 49 (STOPPING) and enter the VIEW TIMES function of the LAP TIME menu to read the stored lap times.

MODE

MODE configuration features the functions allowing the user to interact with the system.

Set selector (2) to MODE position to select MODE configuration.

At the bottom (F), the following data are alternately displayed every time the SET button (3) is pressed:

- BATTERY VOLTAGE
- INSTANT FUEL CONSUMPTION
- LAP TIMER
- MENU (function disabled when vehicle is in motion)

BATTERY VOLTAGE and INSTANT FUEL CONSUMPTION do not allow interaction with the user.

LAP TIME

From MODE configuration, briefly press SET button (3) and select LAP TIME function to use the lap timer. At the bottom (F) of the display "CHRONO" appears and the number of the last time measured is next to it, together with time measured.

Briefly press SET button (3) to start recording a new session with the lap timer. Press again the SET button (3) within the first 10 seconds from when the timer starts, time measurement is cancelled and a new one is started. Press again the SET button (3) after 10 seconds have elapsed from timer start, time measurement is stopped, stored and a new one is started. Stop the time measurement session by pressing the SET (3) pushbutton for several seconds.

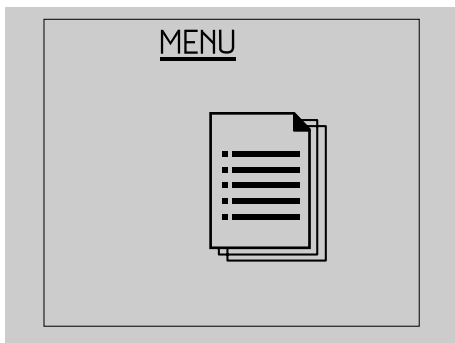

MENU

If vehicle is stopped and selector is set to MODE, configuration menu of the MENU page can be accessed. To enter this function, confirm MENU selection [press SET button (3) for several seconds].

Configuration menu options are:

- EXIT
- SETTINGS
- LAP TIMER
- DIAGNOSTICS
- LANGUAGE

SETTINGS

When confirming SETTINGS selection (pressing SET button (3) for several seconds) the following options are displayed:

- EXIT
- TIME SETTINGS
- GEAR SHIFT INDICATOR
- BACK LIGHTING

- °C/°F
- 12H/24H
- CHANGE THE CODE
- CODE RECOVERY

Time settings

This mode allows you to set the clock. In this function, hours increase by one unit every time the SET button (3) is pressed; when value is 12 or 24, it goes back to 1 if the SET button (3) is pressed again.

AM indication becomes PM or vice versa when time goes from 11:59 to 12:00.

Press the SET button (3) for several seconds to store the value and go to minutes setting mode. Minutes increase by one unit every time the SET button (3) is pressed; when value is 59, it goes back to 0 if the SET button (3) is pressed again.

Press the SET button (3) for several seconds to complete the procedure; the instrument panel sets back to SETTINGS menu.

Gear shift indicator

This function allows you to set the value for the Gear shift indicator threshold. As soon as you enter this function, the display shows "GEAR SHIFT INDICATOR" (if English is the selected language) and the rev counter scale indicates the threshold value.

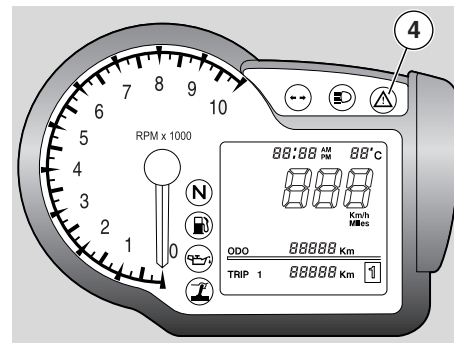

Briefly press the SET (3) pushbutton to increase threshold value by 100 RPM. Once the top limit has been reached, press the pushbutton again to decrease the value.

Press the SET button (3) for several seconds to complete the operation; the display sets back to SETTINGS menu.

When battery is connected for the first time, the instrument panel sets to running-in rpm value, the next time battery is connected it sets to last set value.

- RUNNING-IN RPM: 6500
- MINIMUM RPM (THAT CAN BE SET): 6000
- MAXIMUM RPM (THAT CAN BE SET): 8500

When the set threshold is exceeded, the alarm light (4) on the instrument panel flashes until the value goes below the threshold.

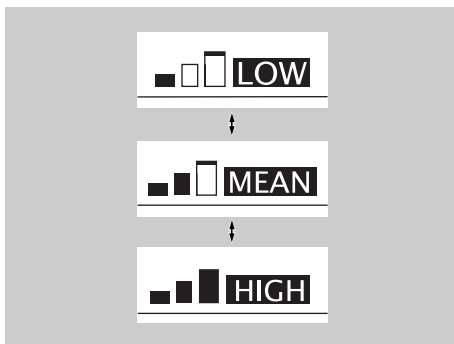

Back lighting

This function allows you to set backlighting: three levels are available.

From this function, every time the SET button (3) is briefly pressed, the following icons are alternately displayed:

- LOW
- MEAN
- HIGH

Press the SET button (3) for several seconds to complete the operation; the instrument panel sets back to SETTINGS menu.

°C/°F

This function allows you to select the unit of measurement for ambient temperature. From this function, every time the SET button (3) is briefly pressed, the following two units of measurement are alternately displayed:

°C

°F

Press the SET button (3) for several seconds to store the data; the instrument panel sets back to SETTINGS menu.

12H/24H

This function allows you to select the time format. From this function, every time the SET button (3) is briefly pressed, the following formats are alternately displayed:

12H

24H

Press the SET button (3) for several seconds to store the data; the instrument panel sets back to SETTINGS menu.

Change the code

This function is used when the old code is available and is to be changed.

Within this function, the following message is displayed:

"INSERT THE OLD CODE"

As soon as the old code is acknowledged, the new code is requested; the following message is displayed:

"INSERT THE NEW CODE"

Once the operation is over, the display goes back to DIAGNOSIS menu. If you entered with the code, this operation will not be allowed.

Once the operation is over, the instrument panel goes back to SETTINGS menu.

Code recovery

This function is used when the old code is not available and you need to change it. In this case it is necessary to insert at least two keys in the ignition switch. The first key is already inserted, a second key is requested with the message:

"INSERT THE 2nd KEY"

The instrument panel remains on in-between these two keys; if the second key is not inserted within 20 seconds the operation is aborted. When the second key is acknowledged, the new code is requested with the message:

"INSERT THE NEW CODE"

Once the operation is over, the display goes back to DIAGNOSIS menu. If you entered with the code, this operation will not be allowed.

Once the operation is over, the instrument panel goes back to SETTINGS menu.

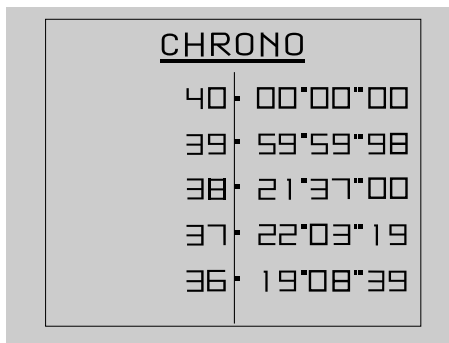

LAP TIMER

When confirming LAP TIMER selection [pressing SET button (3) for several seconds] the following options are displayed:

- EXIT
- VIEW TIMES
- DELETE TIMES

View times

This function also displays the acquired lap times. Briefly press the SET button (3) to scroll the pages with the times measured; press it for several seconds to set the display to LAP TIME menu. If the battery is disconnected, stored times are lost.

Delete times

This function deletes the acquired lap times. Deletion should be confirmed. Once the operation is over, the display goes back to LAP TIMER menu.

DIAGNOSIS

This function interfaces with the systems fitted to the motorcycle to carry out diagnosis. To enable it, you need a special password only available to the **Moto Guzzi Authorized Dealer**.

LANGUAGE

This function allows you to choose the language of any message displayed.

Available options are:

- ITALIANO
- ENGLISH
- FRANCAIS
- DEUTSCH
- ESPAGNOL

Once the operation is over, the display goes back to LANGUAGE menu.

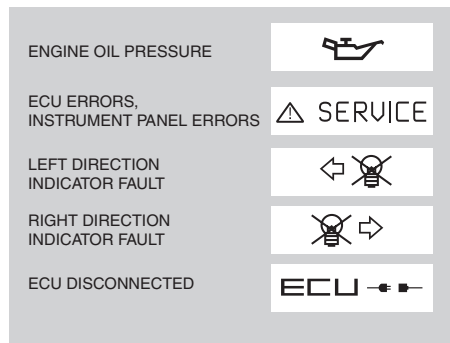

SERVICE INTERVAL

When the scheduled service intervals are reached, an icon is displayed (symbol of a wrench).

Switches on first at: 1,500 km

Then switches on: every 10,000 km

ALARM DISPLAY

In case a serious failure is detected, one that might jeopardize the vehicle or the rider's safety, the display will show an icon indicating the failure cause, at the bottom (F).

Alarms are divided in two groups depending on their priority:

High priority: Engine oil pressure, Errors from control unit and instrument panel errors.

Low priority: Turn indicators and Control unit disconnect.

If there are many alarms with the same priority level, the relevant icons are displayed alternately.

High priority alarms do not allow you to display low priority ones.

If the alarm light and the SERVICE icon briefly come on, it does not mean that there is a failure.

MAIN INDEPENDENT CONTROLS

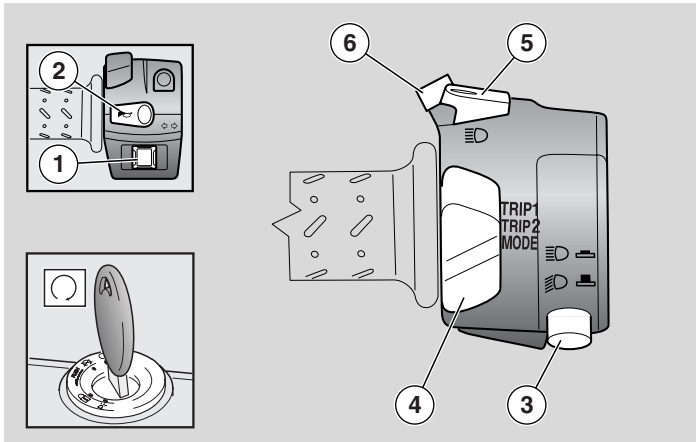

CONTROLS ON LEFT HANDLEBAR

NOTE The electric components only operate when the ignition switch is in the “○” position.

- 1) **DIRECTION INDICATORS SWITCH** (↔)
Move the switch to the left, before turning left; move it to the right before turning right. Push in to cancel the indicators after turning.
- 2) **HORN BUTTON** (🔊)
Press it to operate the horn.

NOTE When the indicator repeater light flashes quickly, this indicates that one or both turn indicator bulbs are burned out. For replacement instructions, please see page 97 (CHANGING THE HEADLIGHT BULBS).

- 3) **LIGHT DIMMER SWITCH:** Set it to “☰” to operate the high beam; set it to “☷” to operate the low beam.
- 4) **LCD CONFIGURATION SELECTOR:**
Select the LCD displayed configuration, see page 33 (MULTIFUNCTION COMPUTER).
- 5) **HIGH BEAM FLASHER BUTTON** (☰)
Allows for the use of the passing lights in case of danger or emergency.

NOTE Release the button to turn off the high beam flasher.

- 6) **SET BUTTON**
Button to scroll and select the displayed menus, see page 33 (MULTIFUNCTION COMPUTER).

CONTROLS ON RIGHT HANDLEBAR

NOTE The electric components only operate when the ignition switch is in the "○" position.

7) **ENGINE STOP SWITCH** (○-⊗)

8) **STARTER BUTTON** (ⓘ)

When the starter button " ⓘ " is pressed, the starter motor will crank the engine. See page 63 (STARTING) for the starting procedure.

⚠ WARNING

Do not operate the engine stop switch "○-⊗" while riding.

This switch serves as a safety or emergency switch. With the switch pressed in position "○", it is possible to start the engine; the engine can be stopped by pressing the switch to position "⊗".

⚠ CAUTION

With the engine stopped and the ignition switch in position "○", the battery may run flat. When the vehicle has come to a standstill and you have stopped the engine, set the ignition switch to position "⊗".

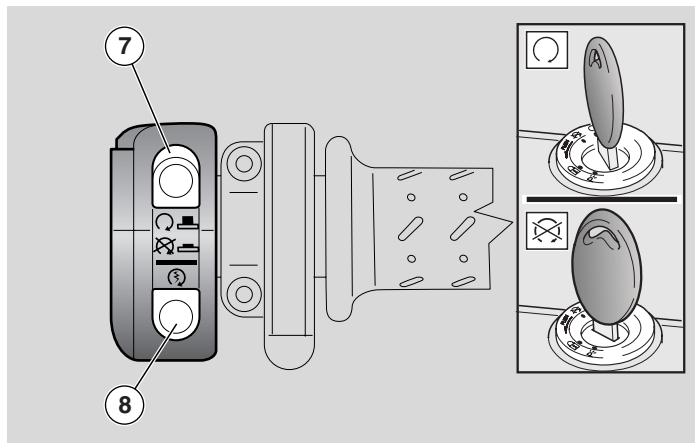

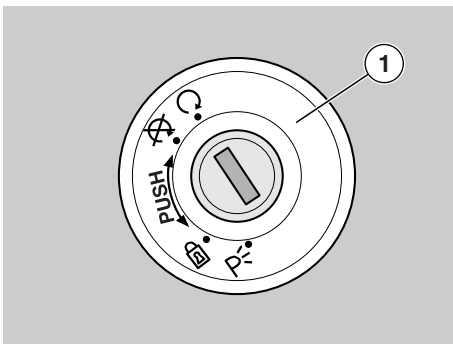

IGNITION SWITCH

The ignition switch (1) is mounted to the top yoke of the steering shaft.

NOTE The key operates the ignition switch/steering lock, the fuel tank lock and the seat lock.

Two keys are supplied together with the vehicle (one spare key).

NOTE Store the spare key in a safe place (other than the vehicle).

NOTE It is possible to store up to 4 keys. Have this procedure carried out by an Authorized **Moto Guzzi** Dealer.

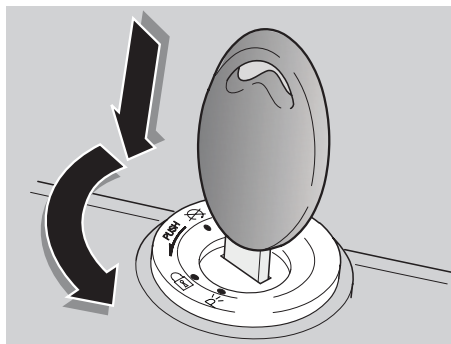

STEERING LOCK

⚠ WARNING

Never turn the key to position "🔒" when riding, or you will lose control of the vehicle.

OPERATION

To lock the steering:

- ◆ Turn the handlebar fully to the left.
- ◆ Turn the key to "🔒".
- ◆ Press the key in and turn it to "🔑" position.

NOTE If necessary, turn on the parking lights, see page 42 (PARKING LIGHTS).

- ◆ Remove the key.

Position	Function	Key removal
🔒 Steering lock	The steering is locked. It is not possible to start the engine or switch on the lights.	It is possible to remove the key.
🚫	Neither the engine, nor the lights will operate.	It is possible to remove the key.
🔄	The engine and the lights can be operated.	It is not possible to remove the key.
P	The engine cannot be started and the parking lights are on	It is possible to remove the key.

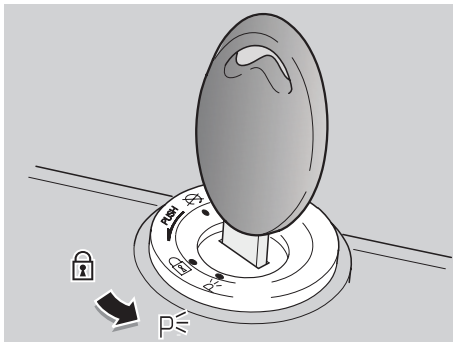

OPERATION

To turn the parking lights on:

- ◆ Lock the steering but do not remove the key (1), see page 41 (STEERING LOCK).
- ◆ Turn the key (1) to “P” (PARKING) position.
- ◆ Check that both front and rear parking lights are on.
- ◆ Remove the key (1).

⚠ CAUTION

The parking lights drain the battery. Do not leave them on for long periods of time to avoid the battery from wearing down. A dead battery prevents you from starting the vehicle.

PARKING LIGHTS

The vehicle is equipped with front and rear parking lights. It is always recommended to park the vehicle in the suitable areas and in any case in lighted locations. If this is not possible, the parking lights are useful whenever it is necessary to park in a dark or poorly lit area and in any case to make the vehicle more visible.

AUXILIARY EQUIPMENT

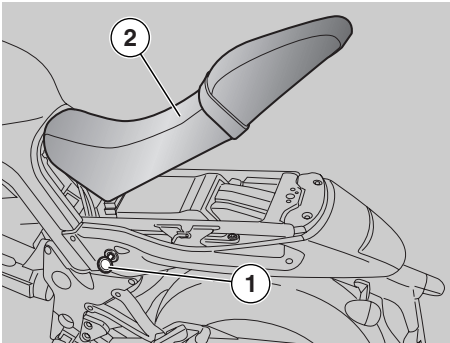

UNLOCKING/LOCKING THE SEAT

- ◆ Place the vehicle on the stand, see page 50 (PUTTING THE VEHICLE ON THE STAND).
- ◆ Insert the key (1) into the seat lock.
- ◆ Turn the key (1) clockwise and push softly onto the rear seat middle to facilitate pin release, then lift and slide out the seat (2) from behind.

NOTE Before lowering and locking the seat (2), make sure that you have not left the key in the tool kit compartment.

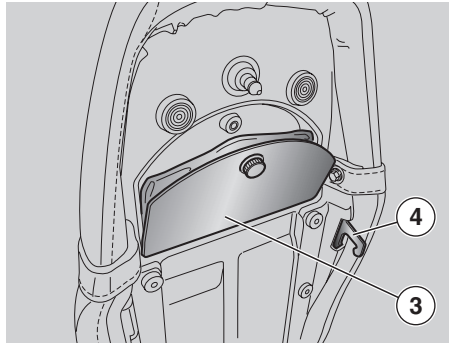

To lock the seat (2):

- ◆ Slide the seat front end into place.
- ◆ Lower the rear end and position the seat so that the two hooks (4) are correctly hooked to the frame fasteners.
- ◆ Push down on the middle of the rear end until the lock clicks shut.

⚠ WARNING

Before riding, make sure that the seat (2) is properly locked.

TOOL KIT COMPARTMENT

To gain access to the tool kit compartment:

- ◆ Remove the seat, see (UNLOCKING/LOCKING THE SEAT), in this page.
- ◆ Remove the cover (3).

The tool kit includes:

- 4, 5 mm bent Allen wrenches (1);
- 10 - 13 mm double fork wrench (2);
- 21 - 22 mm socket wrench (3);
- double-ended cross-head/flat-blade screwdriver (4);
- fuse removing tool (5);
- tool box (6).

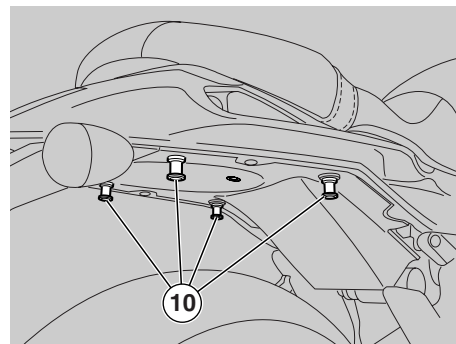
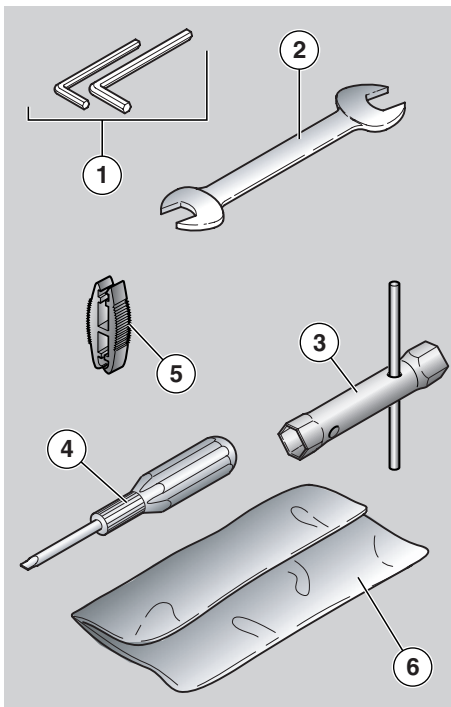

LUGGAGE ANCHOR POINTS

It is possible to fix a small luggage to the seat rear end, it can be positioned using elastic bands to be secured to the four elements (10).

Maximum allowed weight: 11 lb (5 kg).

⚠ WARNING

Carry small luggage only and make sure it is fastened securely.

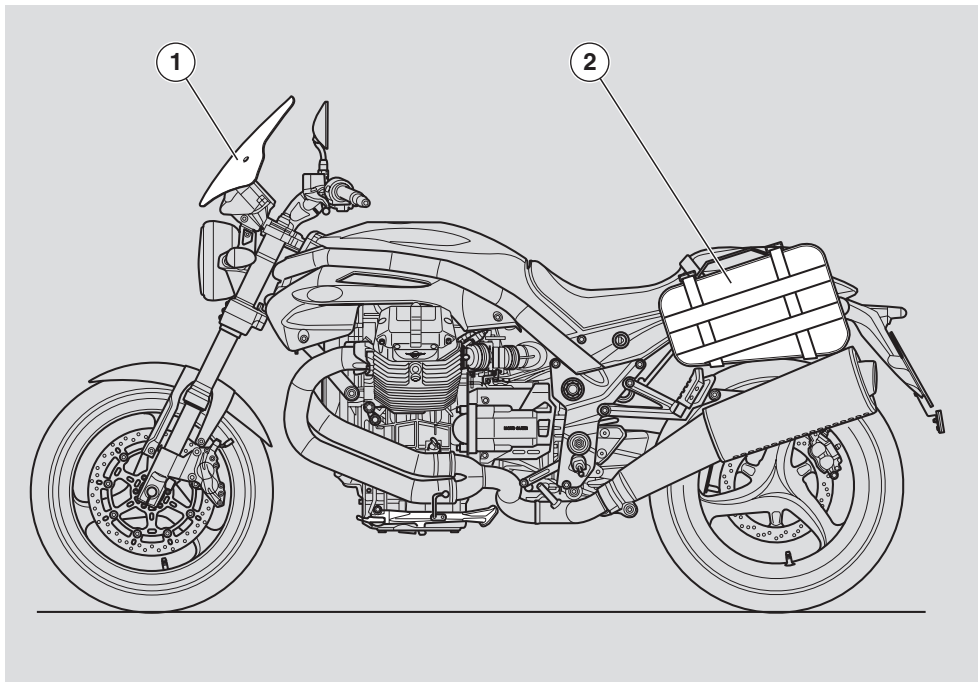

ACCESSORIES OPT

The following accessories are available:

- 1) headlight fairing
- 2) side panniers
 - luggage rack
 - luggage rack bag
 - tank bag (two sizes available).

MAIN COMPONENTS

FUEL

⚠ WARNING

Gasoline is extremely flammable and in some conditions can become explosive. Therefore, it is necessary to refuel and carry out maintenance operations involving the fuel system in a well-ventilated area with the engine off.

Do not refuel or do any maintenance on the fuel system with the engine running. Do not smoke while refueling or near fuel vapors.

Never allow any portion of the fuel system to come in contact with open flames, sparks or other heat sources. Be careful to avoid spilling fuel when you are refueling. Spilled fuel can ignite when it contacts hot engine or exhaust system surfaces. If you accidentally spill some fuel, make sure that it is wiped up or completely evaporated before starting the vehicle.

Since gasoline expands in the fuel tank when the vehicle is sitting out in the sun, never fill the tank completely to the brim. Leave at least one inch of expansion space.

Avoid any contact of the fuel with your skin, and avoid inhalation of fuel vapors. Never attempt to siphon fuel from one container to another using your mouth as suction for a siphon hose.

⚠ WARNING

Gasoline is poisonous and carcinogenic and contains chemical substances that cause birth defects and other reproductive problems. If gasoline should be accidentally spilled on the skin or clothes, immediately wash it off with soap and water and change clothes.

Should gasoline accidentally come in contact with your eyes, flush out with a large quantity of water and immediately contact a health professional. Should you accidentally get gasoline into your mouth, do not induce vomiting. Drink a large quantity of milk or clear water and immediately contact a health professional.

Never try to siphon gasoline by using your mouth. Use a manual pump or a similar system.

If your vehicle overturns, it will leak gasoline which is extremely flammable. Flames or sparks may ignite this which will not only destroy the vehicle but could also do serious damage to surrounding property and cause serious injuries or even death.

ALWAYS KEEP GASOLINE AWAY FROM CHILDREN.

DISPOSE OF UNWANTED GASOLINE PROPERLY, DO NOT DUMP IT INTO STORM SEWERS OR INTO SINKS OR TOILETS.

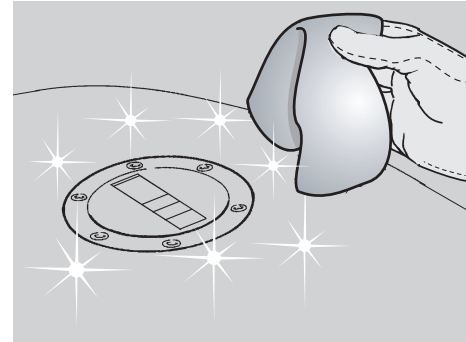

Use only unleaded gasoline minimum octane rating (M+R)/2 method 90.

FUEL TANK CAPACITY

(reserve included): 4.54 US gal (17.2 ℓ).

TANK RESERVE: 0.87 US gal (3.3 ℓ).

REFUEL

To refuel, proceed as follows:

- ◆ Place the vehicle on the stand, see p. 70 (PUTTING THE VEHICLE ON THE STAND).

⚠ CAUTION

If dirt has accumulated on or around the fuel filler cap, wipe the cap and the area around the cap with a clean cloth. Avoid any foreign material from getting into the fuel tank, as this could lead to serious engine damage.

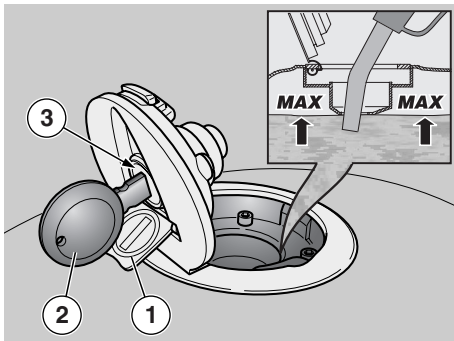

- ◆ Lift the small cover (1).
- ◆ Insert the key (2) in the cap lock (3).
- ◆ Turn the key (2) clockwise, pull it and open the fuel filler cap (4).

⚠ CAUTION

If you use a container or funnel for refueling, make sure that it is perfectly clean.

Any foreign matter getting into the fuel tank may lead to severe damage.

⚠ WARNING

Do not add any additives or other substances to the gasoline.

⚠ WARNING

Do not fill the tank completely. The fuel should never be higher than the bottom of the rim of the filler neck.

- ◆ Refuel.

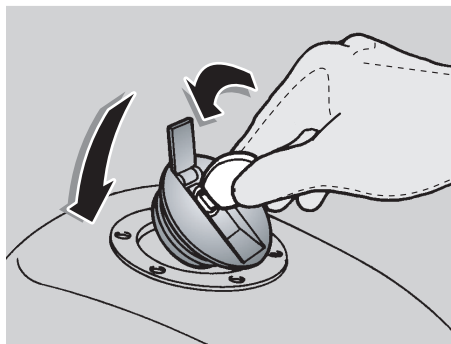

When you finish the refueling operation:

⚠ WARNING

After refueling, replace the fuel filler cap (4) in the correct position.

NOTE It is impossible to close the fuel filler cap without the key.

- ◆ With the key (2) inserted in the lock (3) close the fuel filler cap (4) rotate the key counterclockwise and push it.
- ◆ Release the key (2). At this point the fuel filler cap (4) is closed.

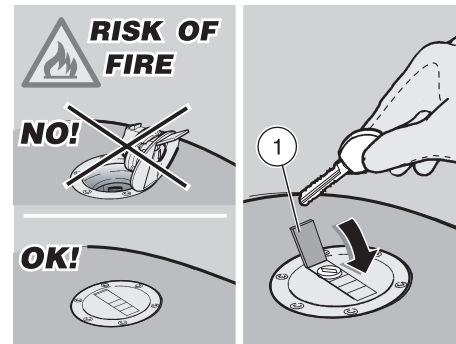

⚠ WARNING

Make sure that the fuel filler cap (4) is properly closed.

- ◆ Remove the key (2).
- ◆ Close the small cover (1).

LUBRICANTS

⚠ WARNING

Proper vehicle lubrication is critical to safe operation. Failure to maintain proper lubricant levels or to use the proper type of clean, new lubricant, can lead to an engine or transmission seizure with subsequent accident, serious injury or death.

⚠ WARNING

Use latex gloves for maintenance operations that require contact with used oil. Used engine oil may cause skin cancer if repeatedly left in contact with the skin for prolonged periods. Although this is

unlikely unless you handle used oil on a daily basis, it is advisable to thoroughly wash your hands with soap and water after handling used oil.

KEEP OIL AWAY FROM CHILDREN.

DISPOSE OF OIL PROPERLY.

⚠ CAUTION

Be very careful not to spill oil when putting oil in your vehicle. Clean up any spilled oil immediately because oil can damage the finish of your vehicle. Also, oil on the tires creates an extremely slippery and therefore dangerous situation.

⚠ CAUTION

In case of oil leakage do not ride your vehicle. Before using the vehicle, have it repaired by your Contact your **Moto Guzzi** Authorized Dealer.

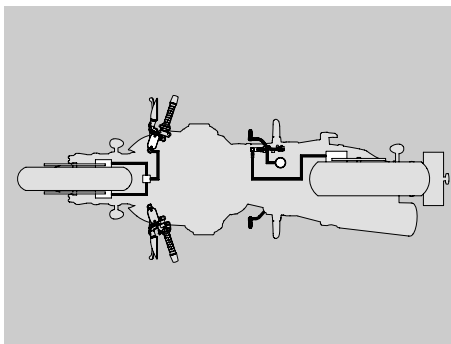

BRAKES

⚠ WARNING

Do not ride your vehicle with worn or malfunctioning brakes! The brakes are the most important safety system of your vehicle, and using the bike with brakes that are anything less than perfect is very likely to lead to a collision or accident, with consequent risk of serious injury or death.

Check brake pad wear, as shown on p. 84 (CHECKING THE BRAKE PADS FOR WEAR). Have your brakes serviced by your Local **Moto Guzzi** Dealer.

Wet conditions seriously impair the performance of your brakes. When the road is wet from rain, you should plan to use double the normal stopping distances since both the brakes themselves and the traction of the tires

on the road are reduced by the presence of water.

Water on the brakes from washing your vehicle, or splashed up from wet roads, or crossing puddles or ditches, can wet the brakes enough to greatly reduce their effectiveness. Failure to heed these warnings may lead to a serious accident with consequent risk of serious injury or even death.

NOTE This vehicle is equipped with front and rear disk brakes operated by independent hydraulic circuits.

The following information applies to both braking systems.

⚠ WARNING

The brakes are extremely important for your safety. Do not use the vehicle if the brakes do not work perfectly. Always check brake efficiency before riding.

⚠ WARNING

Sudden changes in brake lever play or a spongy feel of the lever may indicate problems with the hydraulic system. Please contact a **Moto Guzzi** Authorized Dealer in case you have any doubts on the operation of the braking system and in case you are not able to carry out the normal checks.

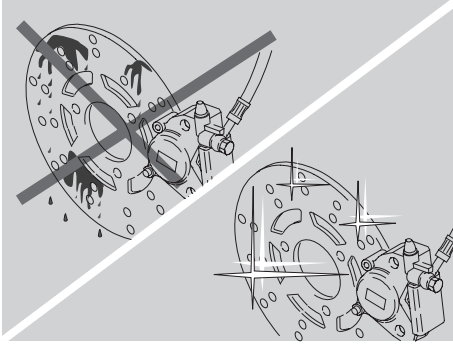

⚠ WARNING

Ensure that the brake disks have not become contaminated with oil or grease, especially after maintenance or inspections.

Check that the brake hoses are not twisted or worn.

Prevent water or dust from accidentally getting into the circuit.

Wear latex gloves when servicing the hydraulic circuit.

Brake fluid can cause severe irritation in the event of contact with eyes or skin.



⚠ WARNING

In the event of accidental contact, flush affected area thoroughly. If fluid has been spilled in the eyes, seek the assistance of an ophthalmologist or a doctor.

DO NOT RELEASE INTO THE ENVIRONMENT.

KEEP AWAY FROM CHILDREN.

⚠ CAUTION

When handling brake fluid, take care not to spill it on plastic or painted parts, or they will be damaged.

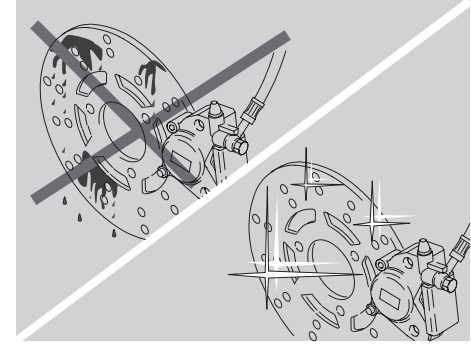

DISK BRAKES

⚠ WARNING

The brakes are key safety components and must be kept in perfect working order; check them before each ride.

A dirty disk will soil the pads, leading to loss of braking efficiency.

Dirty pads must be replaced, while dirty disks must be cleaned with a high-quality degreaser.

Have brake fluid changed every two years by a **Moto Guzzi** Authorized Dealer.

Use the brake fluid recommended in the lubricants table, see page 106 (LUBRICANT CHART).

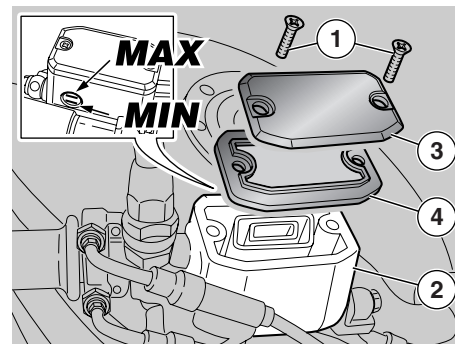
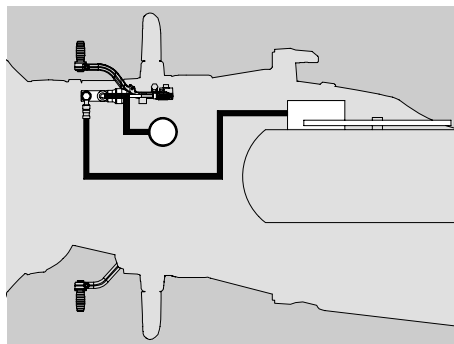
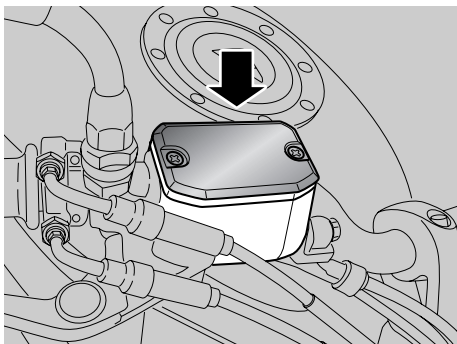

NOTE This vehicle is equipped with front and rear disk brakes operated by independent hydraulic circuits.

The front brake is a twin-disk brake (one disk on either side of the wheel).

The rear brake uses a single disk (fitted to the right side of the wheel).

The following information applies to both braking systems.

Brake fluid level decreases as the brake pads wear down.

The front brake reservoir is located on the right handlebar, close to the front brake lever fitting.

The rear brake reservoir is located on the vehicle right side, close to the rear brake control lever.

NOTE Halve maintenance intervals if you are riding in rainy or dusty conditions, on rough road surfaces or when the vehicle is used for racing.

Check the brake disks for wear after the first 625 mi (1000 km) and then every 1250 mi (2000 km).

Before leaving, check brake fluid level in the reservoirs, see page 50 (FRONT BRAKE), page 51 (REAR BRAKE), and brake pad wear, see page 84 (CHECKING THE BRAKE PADS FOR WEAR).

Have the brake fluid changed every 12500 mi (20,000 km) or every two years by a **Moto Guzzi** Authorized Dealer.

⚠ WARNING

Do not use the vehicle if the braking system is leaking fluid.

FRONT BRAKE CHECK

NOTE Carry out these checks only on a firm, flat surface such as a concrete garage floor.

- ◆ Place the vehicle on the stand, see page 70 (PUTTING THE VEHICLE ON THE STAND).
- ◆ Turn the handlebar fully to the right.
- ◆ Make sure that the fluid level exceeds the "MIN" mark.

MIN= minimum level

MAX= maximum level

If the fluid is below the "MIN" mark:

⚠ CAUTION

Brake fluid level decreases as the brake pads wear down.

- ◆ Check brake pad wear, see page 84 (CHECKING THE BRAKE PADS FOR WEAR) and disk wear.

If the pads and/or the disk do not need replacing, top up fluid level.

TOPPING UP

Carefully read page 48 (BRAKES).

⚠ CAUTION

Brake fluid may spill out. Do not operate the front brake lever if the screws (1) have been loosened or, most important, with the brake fluid reservoir plug removed.

- ◆ Unscrew the two screws (1) of the brake fluid reservoir (2) using a cross-head screwdriver.

⚠ WARNING

Avoid prolonged exposure of brake fluid to air.

Brake fluid is hygroscopic and will absorb moisture from the air.

Keep the brake fluid reservoir open JUST LONG ENOUGH to top up level.

- ◆ Raise and remove the plug (3) together with the screws (1).
- ◆ Remove the gasket (4).

⚠ CAUTION

Do not rock the vehicle from side to side when topping up, or brake fluid may spill out.

Do not add any additives or other products to the fluid.

If you use a funnel or other tools, make sure that they are perfectly clean.

- ◆ Top up reservoir (2) with recommended brake fluid, see page 106 (LUBRICANT CHART), until reaching correct level that is in-between the marks "MIN" and "MAX".

⚠ CAUTION

Do not exceed the "MAX" level mark.

Top up to "MAX" level only after changing the brake pads.

If topped up to "MAX" level with worn pads, brake fluid will spill out when you change the pads at a later time.

Check the brake for proper operation.

If brake lever travel is too long or in the event of loss of braking, contact a **Moto Guzzi** Authorized Dealer, as the system may need bleeding.

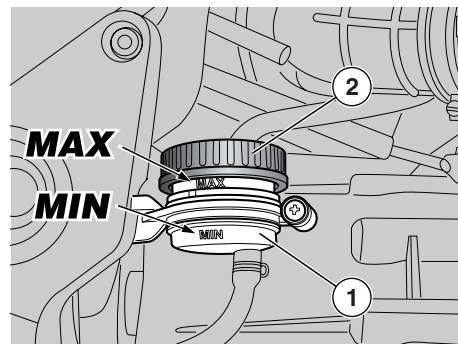

REAR BRAKE

CHECK

NOTE Perform these checks only on a firm, flat surface such as a concrete garage floor.

- ◆ Keep the vehicle upright, so as to keep the fluid in the reservoir (1) level with the plug (2).
- ◆ Make sure that the fluid level exceeds the "MIN" mark.
MIN= minimum level
MAX= maximum level

If the fluid is below the "MIN" mark:

⚠ CAUTION

Brake fluid level decreases as the brake pads wear down.

- ◆ Check brake pad wear, see page 84 (CHECKING THE BRAKE PADS FOR WEAR) and disk wear.
If the pads and/or the disk do not need replacing, top up fluid level.

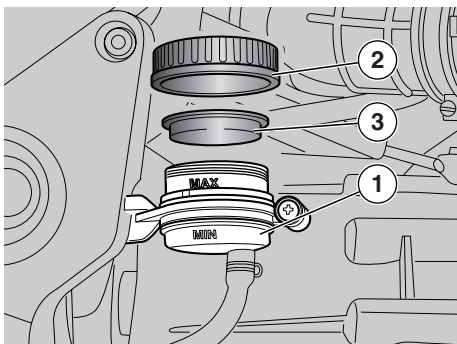

TOPPING UP

Read page 48 (BRAKES).

⚠ CAUTION

Be careful, brake fluid may spill out. Do not operate the rear brake lever if the brake fluid reservoir plug has been loosened or removed.

⚠ WARNING

Avoid prolonged exposure of brake fluid to air.

Brake fluid is hygroscopic and will absorb moisture from the air.

Keep the brake fluid reservoir open **JUST LONG ENOUGH** to top up level.

- ◆ Unscrew and remove the plug (2).

⚠ CAUTION

Make sure the fluid in the reservoir is level with the reservoir rim (horizontal) to avoid spilling fluid when topping up.

Do not add any additives or other products to the fluid.

If you use a funnel or other tools, make sure that they are perfectly clean.

- ◆ Remove the gasket (3).
- ◆ Top up reservoir (1) with recommended brake fluid, see page 106 (LUBRICANT CHART), until reaching correct level that is in-between the marks "MIN" and "MAX".

⚠ CAUTION

Top up to "MAX" level only after changing the brake pads. If topped up to "MAX" level with worn pads, brake fluid will spill out when you change the pads at a later time.

Check the brake for proper operation.

If brake lever travel is too long or in the event of loss of braking, contact a **Moto Guzzi** Authorized Dealer, as the system may need bleeding.



CLUTCH FLUID - recommendations

NOTE This vehicle is fitted with a hydraulically-controlled clutch.

⚠ CAUTION

Any sudden changes in play or hardness in the clutch lever are warning signs of problems in the hydraulic circuit.

Please contact a **Moto Guzzi** Authorized Dealer if you have any doubts on the operation of the system and in case you are not able to carry out the normal checks.

⚠ CAUTION

Make sure the clutch hose is not twisted or worn.

Prevent water or dust from accidentally getting into the circuit.

Wear latex gloves when servicing the hydraulic circuit.

Clutch fluid is an irritant. Avoid contact with eyes or skin.

In the event of accidental contact, flush affected area thoroughly. Seek medical attention or, if fluid has been spilled in the eyes, seek the assistance of an ophthalmologist.

DO NOT RELEASE INTO THE ENVIRONMENT.

KEEP AWAY FROM CHILDREN.

When handling clutch fluid, take care not to spill it onto plastic or paint-finished parts or they will damage.

Have clutch fluid changed every two years by a **Moto Guzzi** Authorized Dealer.

Use the fluid recommended in the lubricants table, see page 106 (LUBRICANT CHART).

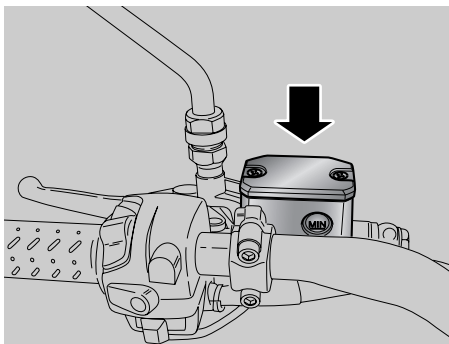

The clutch reservoir is located on the left handlebar near the clutch lever fitting.

NOTE Halve maintenance intervals if you are riding in rainy or dusty conditions, on rough road surfaces or when the vehicle is used for racing.

Before leaving, check the fluid level in the reservoir, see page 53 (CLUTCH), have it changed every two years by a **Moto Guzzi** Authorized Dealer.

⚠ WARNING

Do not ride if the clutch hydraulic circuit is leaking.

CLUTCH

⚠ WARNING

Do not ride your vehicle with a worn or malfunctioning clutch! The clutch is an important safety system of your vehicle, and using the bike with a clutch that is anything less than perfect is very likely to lead to a collision or accident, with consequent risk of serious injury or death.

NOTE This vehicle is equipped with hydraulic clutch control.

⚠ WARNING

The clutch is extremely important for your safety. Do not use the vehicle if the clutch does not work perfectly. Always check clutch efficiency before riding.

NOTE Halve maintenance intervals if you are riding in rainy or dusty conditions, on rough road surfaces or when the vehicle is used for racing.

Every 10000 km (6250 mi) have the clutch inspected by a **Moto Guzzi** Authorized Dealer.

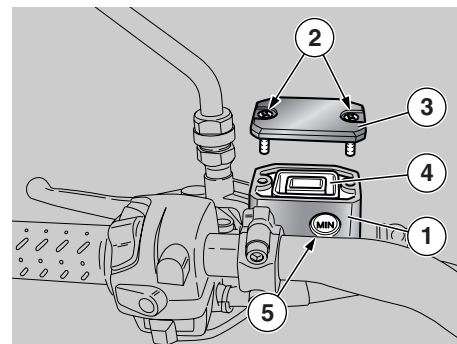
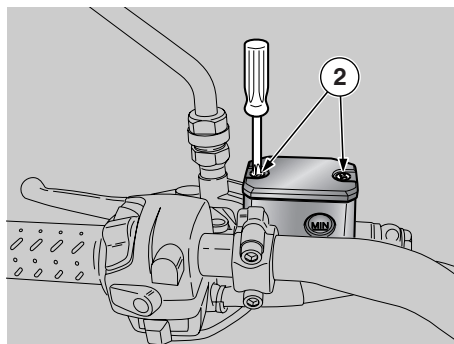
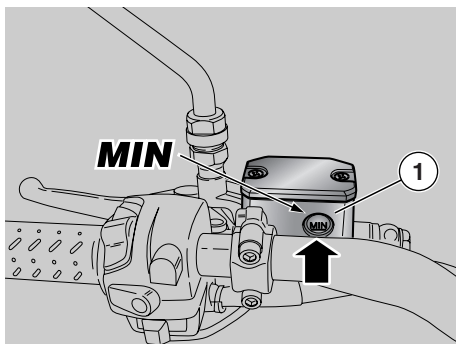

CHECK

- ◆ Place the vehicle on the stand, see page 70 (PUTTING THE VEHICLE ON THE STAND).
- ◆ Turn the handlebar partially to the right, so that the fluid inside the clutch reservoir is parallel to the reservoir edge (1) (see figure).
- ◆ Make sure that the fluid level exceeds the "MIN" mark.
- ◆ **MIN**= minimum level
- ◆ Top up if the fluid does not reach at least the "**MIN**" mark.

TOPPING UP

Carefully read page 52 (CLUTCH FLUID - recommendations).

⚠ CAUTION

Danger: clutch fluid could leak out. Never operate the clutch lever when the reservoir plug is loose or has been removed.

⚠ WARNING

Avoid long exposure of clutch fluid to air.

Clutch fluid is hygroscopic and will absorb moisture from the air.

Keep the clutch fluid reservoir open JUST LONG ENOUGH to top up level.

⚠ CAUTION

Place a cloth under the clutch reservoir to protect it from any fluid spillage.

- ◆ Unscrew the two screws (2) of the clutch fluid reservoir (1) using a small cross-head screwdriver.

⚠ CAUTION

Do not rock the motorcycle from side to side when topping up or clutch fluid will spill out.

Do not add any additives or other products to the fluid.

If you use a funnel or other tools, make sure that they are perfectly clean.

- ◆ Raise and remove the plug (3) together with the screws (2).
- ◆ Remove the gasket (4).

NOTE As a reference to obtain "**MAX**" level, top up until fluid completely covers sight glass (5), keep the clutch reservoir upright.

- ◆ Top up reservoir (1) using recommended clutch fluid, see page 106 (LUBRICANT CHART), until reaching the correct level.

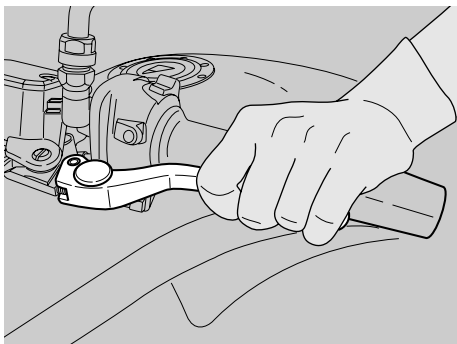

⚠ CAUTION

Do not exceed the "MAX" level mark.

- ◆ Fit back the gasket (4) in its seat correctly.
- ◆ Refit the cover (3).
- ◆ Fit and tighten the screws (2).

⚠ WARNING

Check the clutch for proper operation. If clutch lever travel is too long or in the event of clutch inefficiency, contact a **Moto Guzzi** Authorized Dealer, as the system may need bleeding.

TIRES

This vehicle is equipped with tubeless tires.

NOTE Halve maintenance intervals if you are riding in rainy or dusty conditions, on rough road surfaces or when the vehicle is used for racing.

⚠ WARNING

Check the inflation pressure at ambient temperature every two weeks.

Check every 930 mi (1500 km) tire condition and pressure at ambient temperature, see page 103 (TECHNICAL DATA).

Measuring pressure on hot tires will lead to inaccurate measurement.

It is especially important to measure tire pressure before and after a long trip.

Overinflated tires will not absorb bumps when riding on rough road surfaces and resulting vibration is transferred through the handlebar, giving a hard ride and reducing tire grip especially during cornering.

Conversely, underinflation will put more stress on the sidewalls (1) and the tire may slip on the rim or even come off the rim, leading to loss of control.

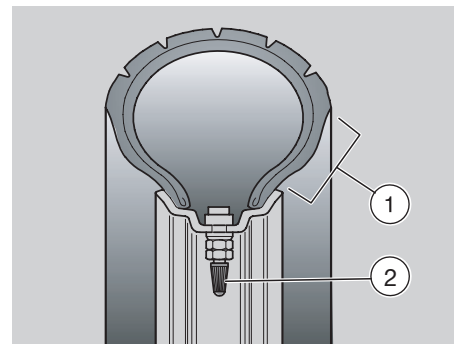

The tires could come off the rims under hard braking.

Finally, the vehicle could skid during cornering.

⚠ WARNING

Inspect tire surface condition and check for wear, as worn tires lead to poor road holding and handling.

Some of the tires approved for this vehicle are equipped with wear indicators.

There are several kinds of wear indicators. For more information on how to check the tires for wear, contact your Dealer.

Visually inspect the tires for wear and have them changed if worn.

Have a tire changed when worn or punctured, if the puncture in the tread is larger than 5 mm.

Have the wheels balanced after each tire repair.

⚠ WARNING

Spare tires should be of the recommended type and model, see page 103 (TECHNICAL DATA); using different tires than the specified ones negatively affects vehicle handling.

Do not install tube tires on tubeless tire rims or vice versa.

Make sure that caps are in place on the valves (2), or the tires may deflate suddenly.

Tire replacement and repair, and wheel servicing and balancing are delicate operations that should be carried out using adequate tools and are best left to experienced mechanics.

For this reason, it is advisable to have these operations carried out by a **Moto Guzzi Authorized Dealer** or by a qualified tire repairer.

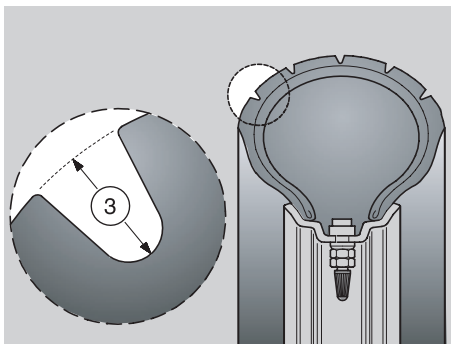

If the tires are new, they may still be covered with a slippery film: drive carefully for the first few miles. Never apply non-specific products to the tires. Old tires, even if not completely worn down, may become hard and provide poor grip.

If so, have them replaced.

MINIMUM TREAD DEPTH (3):

front and rear 2 mm ( 3 mm), anyway not less than required by the regulations in force in the country where the vehicle is used.

ENGINE OIL

⚠ WARNING

Prolonged or repeated contact with engine oil may cause severe skin damage.

Wash your hands carefully after use.



KEEP AWAY FROM CHILDREN.

DO NOT RELEASE OIL INTO THE ENVIRONMENT.

Put it in a sealed container and take it to the filling station where you usually buy it or else to an oil salvage facility.

If any maintenance operations are required, it is advisable to use latex gloves.

⚠ CAUTION

If the LED " " and the engine oil pressure icon " " come on during regular engine operation, it means that engine oil pressure in the circuit is low. If so, check engine oil level, see page 56 (CHECKING AND TOPPING UP ENGINE OIL LEVEL). If insufficient, immediately stop the engine and top up. Have the system checked by your **Moto Guzzi Authorized Dealer**.

⚠ CAUTION

If the engine oil pressure LED “ SERVICE” come on during engine normal operation, it means that the engine oil pressure sensor is faulty. If so, check engine oil level, see page 56 (CHECKING AND TOPPING UP ENGINE OIL LEVEL). If insufficient, immediately stop the engine and top up. Have the system checked by your **Moto Guzzi** Authorized Dealer.



⚠ CAUTION

Proceed with care.

Do not spill the oil!

Take care not to smear any component, the area in which you are working and the surrounding area. Carefully remove any trace of oil.

In case of leakage or malfunction, contact a **Moto Guzzi** Authorized Dealer.

Periodically check the engine oil level, see page 76 (CHECKING AND TOPPING UP ENGINE OIL LEVEL).

To change engine oil, see page 72 (SCHEDULED MAINTENANCE CHART) and page 76 (CHECKING AND TOPPING UP ENGINE OIL LEVEL).

NOTE Use high quality oil, see page 106 (LUBRICANT CHART).

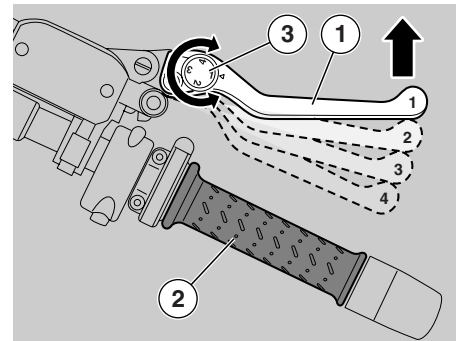

ADJUSTING THE FRONT BRAKE LEVER AND THE CLUTCH LEVER

The grab distance of the lever (1) [distance from the grip (2)] can be adjusted by rotating the adjuster (3).

Positions “1” and “4” correspond to an approximate lever-handgrip distance respectively of 105 and 85 mm.

Positions “2” and “3” correspond to intermediate distances.

◆ ★ Push the lever (1) forward and turn dial (3) until the required number matches the arrow.

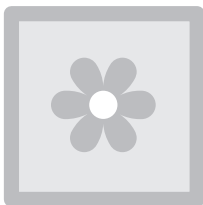

CATALYTIC SILENCER

WARNING

Do not park the vehicle close to dried brushwood or in places where children are likely to come in contact with it, because the catalytic muffler reaches very high operating temperature. Pay utmost attention and avoid any contact until it has cooled down.

This vehicle fits a silencer with "platinum-palladium-rhodium" three-way metal catalytic converter.

This device provides for the oxidation of the CO (carbon monoxide) and of the HC (unburned hydrocarbons) contained in the exhaust gases, changing them into carbon dioxide and steam, respectively.

CAUTION

Use unleaded fuel only. Lead will damage the catalytic converter.

EXHAUST MUFFLER/EXHAUST SILENCER

WARNING

Tampering with the noise control system is prohibited.

Owners are warned that the law may prohibit:

- The removal or rendering inoperative by any person, other than for purposes of maintenance, repair or replacement, of any device or element of design incorporated into any new vehicle - for the purpose of noise control - prior to its sale or delivery to the ultimate purchaser or while it is in use;
- The use of the vehicle after such device or element of design has been removed or rendered inoperative by any person.

Check the exhaust muffler/silencer and the silencer pipes; make sure that they show no traces of rust or holes and that the exhaust system is operating properly.

If the exhaust system becomes noisy, immediately contact your **Moto Guzzi** Authorized Dealer.

INSTRUCTIONS FOR USE

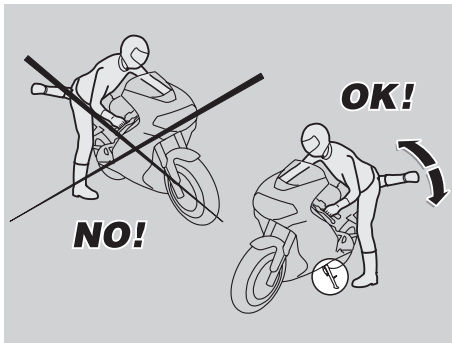

GETTING ON AND OFF THE VEHICLE

Follow the instructions below closely in order to avoid injury to persons, damage to property and to the vehicle in the event the rider or passenger falls off the vehicle and/or the vehicle falls or overturns.

⚠ WARNING

Risk of falling and overturning. Proceed with care.

When getting on and off the vehicle, make sure nothing is restricting your movements; you should not be holding any objects in your hands, such as helmet, gloves or glasses.

Always get on and off the vehicle from the left side and with the side stand down.

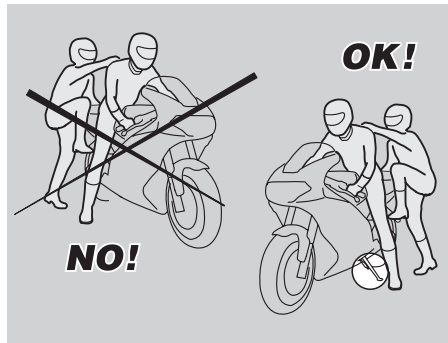

⚠ CAUTION

Do not rest your (and your passenger's) weight on the side stand.

The stand has been designed to support the weight of the vehicle and a minimal load, without the added weight of rider and/or passenger.

The purpose of the side stand is to prevent the vehicle from falling or overturning while rider and passenger get on the vehicle and the stand should not be used to support the weight of rider and passenger.

While getting on and off, the vehicle may become unstable due to its weight, and the vehicle may fall or overturn.

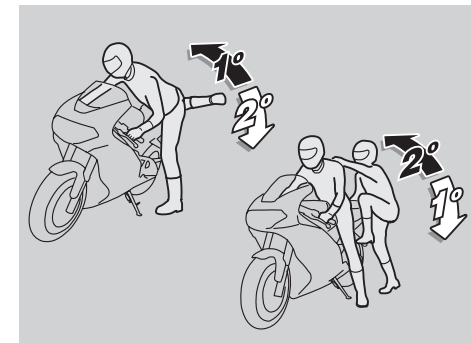
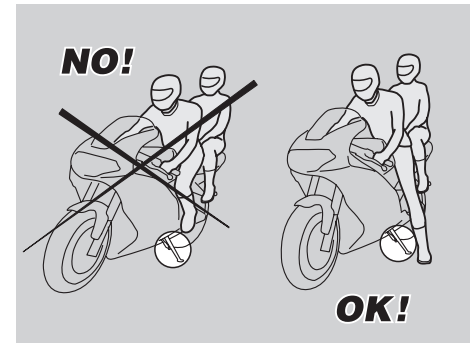

NOTE The rider must get on the vehicle first and get off last to ensure he/she has control and balance of the vehicle while the passenger is mounting or dismounting.

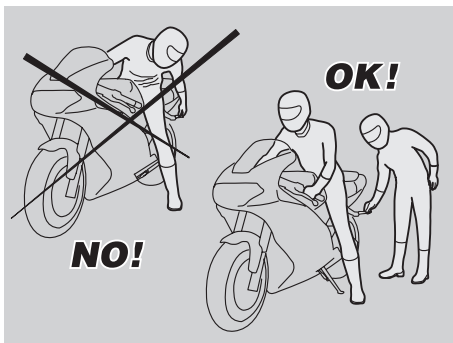

When getting on and off the vehicle, the passenger must move carefully to avoid causing imbalance.

NOTE The rider must instruct the passenger on how to safely get on and off the vehicle.

The vehicle is equipped with passenger footpegs to make mounting and dismounting easier. The passenger must always use the left footpeg to get on and off the vehicle.

Never get off or attempt to get off the vehicle by jumping or stretch your leg to put your foot on the ground to dismount. These are incorrect procedures that will affect the stability and balance of the vehicle.

NOTE Any bags or objects strapped to the rear of the vehicle can represent an obstacle while getting on and off.

Swing your right leg over the seat in a controlled movement so as not to hit the

tail section or luggage at the rear and avoid resulting imbalance.

GETTING ON THE VEHICLE

- ◆ Grasp the handlebar correctly and get on the vehicle without resting your weight on the side stand.

NOTE If you cannot reach the ground with both feet when sitting astride the vehicle, place your right foot on the ground (if you lose balance, the side stand will prevent a fall on the left side) and be ready to put your left foot to the ground to help keep your balance.

- ◆ Place both feet on the ground, straighten the vehicle and make sure to balance it fully.

NOTE The rider must not fold out or attempt to fold out the passenger footpeg while seated astride the vehicle, because this might compromise the stability and balance of the vehicle.

- ◆ Ask your passenger to fold out both passenger footpegs.
- ◆ Instruct the passenger on how to safely get on the vehicle.
- ◆ Pull the side stand fully up using your left foot.

GETTING OFF THE VEHICLE

- ◆ Select an appropriate location for parking, see page 69 (PARKING).
- ◆ Stop the vehicle, see page 69 (STOPPING).

⚠ WARNING

Make sure the ground is firm and level and free from obstacles.

- ◆ Put your left heel on the side stand lever and push the side stand fully down.

NOTE If you cannot reach the ground with both feet when sitting astride the vehicle, place your right foot on the ground (if you lose balance, the side stand will prevent a fall on the left side) and be ready to put your left foot to the ground to help keep your balance.

- ◆ Place both feet on the ground and balance the vehicle keeping it upright.
- ◆ Instruct the passenger on how to safely get off the vehicle.

⚠ WARNING

Risk of falling and overturning.

Make sure that the passenger has dismounted.

Do not rest your weight on the side stand.

- ◆ Lean the vehicle to the side until the stand is resting on the ground.
- ◆ Keep your hands firmly on the handlebar and get off the vehicle.
- ◆ Turn the handlebar fully to the left.
- ◆ Fold up the passenger footpegs.

⚠ CAUTION

Make sure that the vehicle is stable.

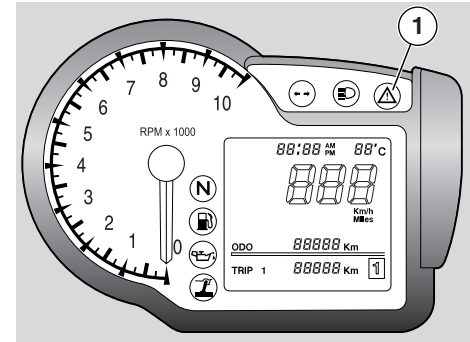

PRE-RIDE CHECKS

⚠ WARNING

Before starting, always perform vehicle pre-ride checks, to ensure safe operation see page 62 (PRE-RIDE CHECKS CHART).

Failure to perform these checks may lead to severe personal injury or vehicle damage.

Do not hesitate to contact your **Moto Guzzi** Authorized Dealer if you need clarifications about the operation of vehicle controls or if you suspect or have identified a malfunction.

A quick pre-ride check takes just a few minutes and greatly improves your safety.

NOTE This vehicle is equipped with an electronic engine control unit capable of detecting abnormal operation in real time and storing faults.

Any time the ignition switch is set to “

⚠ CAUTION

If the alarm LED “

⚠ CAUTION

After the first 930 mi (1500 km) and every 6250 mi (10000 km) thereafter, the right display will show icon “

In this case, have a **Moto Guzzi** Authorized Dealer perform all service operations as indicated in the scheduled maintenance chart, see page 72 (SCHEDULED MAINTENANCE CHART).

PRE-RIDE CHECKS CHART

Part	Check	page
Front and rear disk brakes	Check for proper operation, check lever free play, fluid level and check for leaks. Check the pads for wear. If necessary, top up the fluid reservoirs.	52, 49, 50, 51, 84
Throttle	Check for smooth operation; throttle should snap fully open and closed at all positions of the steering. Adjust and/or lubricate as required.	85
Engine oil	Check and/or top up as required.	56, 80
Wheels / tires	Check tire surface, inflation pressure. Check for wear or damage. Remove any objects trapped in the tread.	55
Brake levers	Make sure that they work smoothly. Lubricate the joints if necessary (rear brake control).	-
Clutch	Check clutch operation, free travel of control lever (free play with a cold engine must be less than 1 mm). The clutch must not jerk and/or slip when operated.	-
Steering	Steering should rotate smoothly and evenly. There should be no play or looseness.	-
Side stand Center stand	Check its operation. No friction during up and down movement, springs must ensure full retraction. Lubricate joints and connections, if necessary. Check stand switch for proper operation.	88, 92
Fastening elements	Make sure that the fastening elements are not loose. Adjust or tighten as required.	-
Fuel tank	Check fuel level and top up, if necessary. Check the circuit for leaks. Make sure the filler plug is tightened securely.	46
Engine stop switch (○ - ⊗)	Make sure that it operates correctly.	40
Lights, warning lights, horn, rear brake light switches and electrical devices	Check the proper operation of the acoustic and visual devices. Change the bulbs or repair if faulty.	97, 98, 98, 98
Transmission fluid	Check. If level needs topping up, contact a Moto Guzzi Authorized Dealer.	80

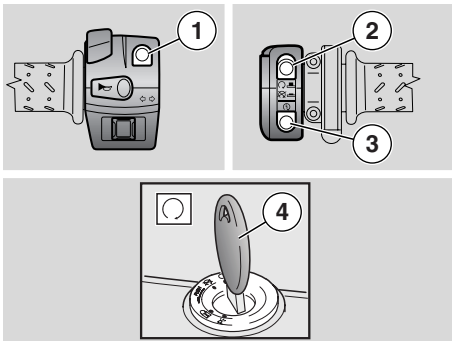

STARTING

⚠ WARNING

This is a high-performance vehicle. We recommend that you become familiar with it gradually using the greatest care.

Do not store any objects on the inside of the headlight fairing (between the handlebar and the instrument panel) as this could impair handlebar movement or hide the instrument panel from your vision.

NOTE Before starting the engine, carefully read section "Safe Riding", see page 5 (SAFE RIDING).

⚠ WARNING

Exhaust gases contain carbon monoxide, which is extremely toxic if inhaled.

Do not start the engine in an enclosed space or poorly ventilated area.

Failure to observe this warning may lead to loss of consciousness or even death by asphyxia.

NOTE With the side stand down, the engine can be started only if the gear is in neutral; if you attempt to engage a gear with the stand down, the engine will stop.

With the side stand up, you can start the engine in neutral or with a gear engaged and the clutch lever pulled in.

- ◆ Sit astride the vehicle, see page 59 (GETTING ON AND OFF THE VEHICLE).
- ◆ Make sure the stand is fully up.

- ◆ Make sure that the dimmer switch (1) is in position "☀".
- ◆ Set the engine stop switch (2) to position "⊙".
- ◆ Turn the key (4) and set the ignition switch to position "⊙".

The following happens:

- the parking lights come on;
- all warning lights on the instrument panel come on;
- the LCD shows the logo "GRISO" for two seconds;
- the speed indicator and fuel gauge indexes reach end of scale, rpm index moves to max. set value;
- as soon as the first check routine is over, the warning lights go off, the instruments indicate the current value and the LCD displays the configuration set on the selector;
- the fuel pump puts the feed circuit under pressure and hums for approximately three seconds.

⚠ CAUTION

If the low fuel warning light "⛽" (7) on the instrument panel comes on, it means that there is 0.87 gallon (3.3 l) of fuel left in the tank. Refuel as soon as possible, see page 46 (FUEL).

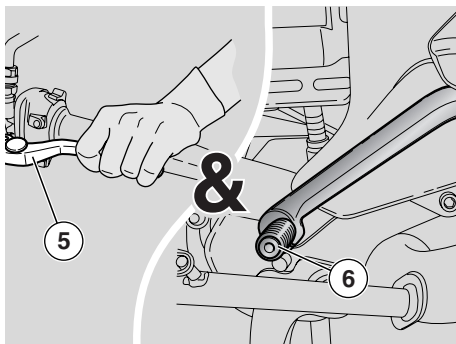

- ◆ Completely pull the front brake lever.
- ◆ Completely pull the clutch lever (5) and set the gearshift lever (9) to neutral [green LED “N” on].

NOTE Hold the clutch lever (5) completely pulled until the engine has started.

NOTE In case of low ambient temperature (close to or lower than 0°C – 32 °F), see page 65 (STARTING THE ENGINE FROM COLD).

- ◆ Press the starter button “(1)” (3), do not accelerate, and immediately release it, the control unit will manage the starting procedure on its own.
- The low beam comes on.

⚠ CAUTION

If the alarm light “⚠” and the engine oil pressure icon “(4)” are still on, or come on during engine normal operation, it means that the oil pressure in the circuit is low.

⚠ WARNING

If the throttle sticks open, it may cause a collision with another vehicle, or an accident.

If the throttle sticks, kill the engine with the engine stop switch located on the right handlebar. Do not attempt to restart the engine until the throttle has been repaired and works perfectly. Failure to obey this warning can lead to a runaway resulting in serious injury or even death.

Your vehicle is equipped with a double cable throttle. One cable opens the throttle when you rotate the throttle grip toward you; the other closes the throttle when you rotate the grip away from you. It is essential, when you release the throttle grip, that it automatically return to the idle position.

This double cable arrangement enhances safety by providing for positive closing of the throttle.

In the event of a throttle sticking emergency, always kill the engine using the engine stop switch located near the throttle grip on the right handlebar. Never use your vehicle if the throttle

does not automatically go back to the idle position when the throttle grip is released. Contact your Local **Moto Guzzi Dealer** for repairs. Failure to heed this warning can lead to a serious accident and subsequent injury or even death.

- ◆ Keep at least one brake operated and do not accelerate until you are ready to move off.

⚠ CAUTION

Never move off abruptly with a cold engine.

To reduce emissions and fuel consumption, ride slowly until covering several miles to warm the engine up to operating temperature.

⚠ CAUTION

If the alarm LED “⚠” and the “⚠ SERVICE” diagnosis icon come on during engine normal operation, it means that the control unit has detected a failure. In most cases, the engine will keep running, although giving less performance. Immediately contact a **Moto Guzzi Authorized Dealer**.

STARTING THE ENGINE FROM COLD

The vehicle is fitted with an automatic cold start device and does not require any precaution for cold starting.

In case of low ambient temperature (close to or lower than 32°F / 0°C), the automatic cold start switches on and increases the rpm until reaching optimum engine temperature and switches off automatically.

⚠ CAUTION

The automatic cold start cannot be manually operated.

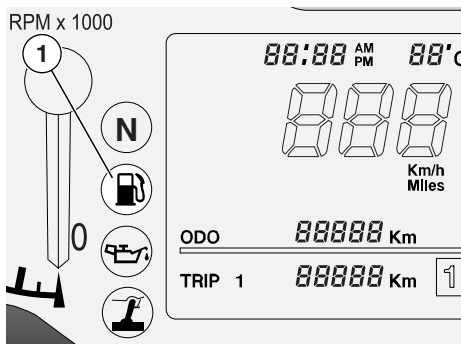

MOVING OFF AND RIDING

⚠ WARNING

This is a high-performance vehicle and we recommend that you become familiar with it gradually using the greatest care.

Do not store any objects between the handlebar and the instrument panel, this could impair handlebar movement or hide the instrument panel from your vision.

NOTE Before moving off, carefully read section "Safe Riding", see page 5 (SAFE RIDING).

⚠ CAUTION

If the low fuel warning light "⛽" (1) on the instrument panel comes on when riding, it means that there is 0.87 gallon (3.3 ℓ) of fuel left in the tank.

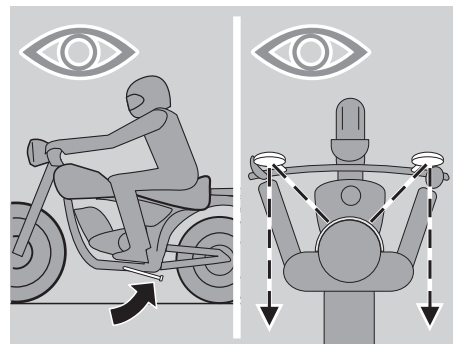

Refuel as soon as possible, see page 46 (FUEL).

⚠ WARNING

If you are riding solo, make sure the passenger footpegs are folded up before moving off.

While riding, keep your hands on the handlebar and your feet on the footpegs.

NEVER RIDE IN ANY POSITION OTHER THAN THE RECOMMENDED RIDING POSITION.

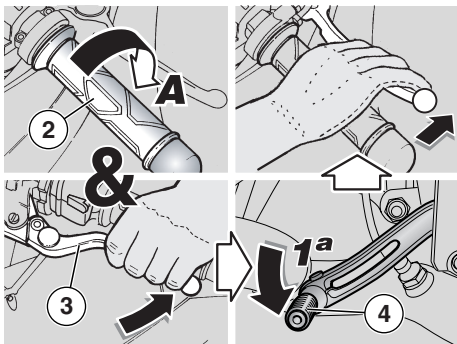

⚠ WARNING

If you are riding with a passenger, give your passenger proper instructions to avoid problems when maneuvering.

Before moving off, make sure the stand is fully up.

To move off:

- ◆ Start the engine, see page 63 (STARTING).
- ◆ Adjust the rearview mirrors.
- ◆ With the throttle twistgrip (2) released (Pos. A), let engine idle and pull the clutch lever (3) fully in.
- ◆ Push down the gearshift lever (4) to engage the first gear.
- ◆ Release the brake lever (you had pulled it when you started the engine).

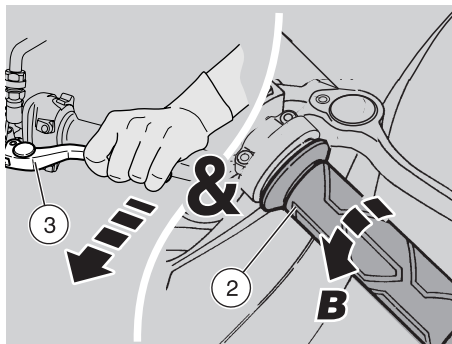

⚠ WARNING

On moving off, release the clutch lever gradually, otherwise the engine may stall or the vehicle may jerk forwards.

Never accelerate abruptly or excessively when releasing the clutch lever, otherwise the clutch may "slip" (if released slowly) or the vehicle may do an unexpected "wheelie" (if you release the clutch quickly).

- ◆ Slowly release the clutch lever (3) while opening the throttle slightly (2) (Pos.B). The vehicle will start moving.
- ◆ Ride at slow speed until covering several miles to warm the engine up to operating temperature.

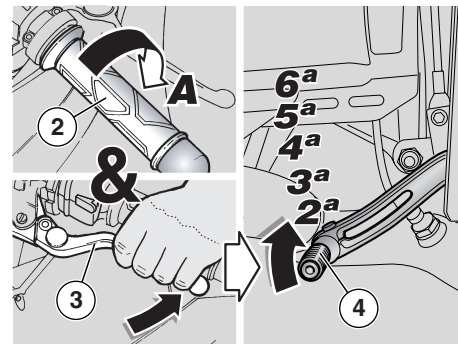

⚠ CAUTION

Do not exceed recommended rpm, see page 68 (RUNNING-IN).

- ◆ Increase your speed by gradually rotating the throttle grip (2) (Pos.B), without exceeding the recommended rpm, see page 68 (RUNNING-IN)

To engage the second gear:

⚠ CAUTION

Work the controls quickly.

Never let the engine operate at too low a speed.

- ◆ Release the throttle twistgrip (2) (Pos.A), pull the clutch lever (3) and lift the gearshift lever (4). Release the clutch lever (3) and accelerate.
- ◆ Repeat the last two steps and shift up.

⚠ CAUTION

If the LED "⚠" and the engine oil pressure icon "🛢" come on during regular engine operation, it means that engine oil pressure in the circuit is low. If so, check engine oil level, see page 56 (CHECKING AND TOPPING UP ENGINE OIL LEVEL). If insufficient, immediately stop the engine and top up. Have the system checked by your **Moto Guzzi** Authorized Dealer.

Change to a lower gear (downshift):

- ◆ When riding downhill or when braking, use engine braking to increase braking effect.
- ◆ When riding uphill, if the gear engaged is too high for your speed and engine rpm is dropping.

⚠ CAUTION

When shifting down, always select the next lower gear or you will cause the engine to race (exceed red line rpm limit).

Before and during a downshift, release the throttle grip and slow down a bit in order to avoid hitting the "red line".

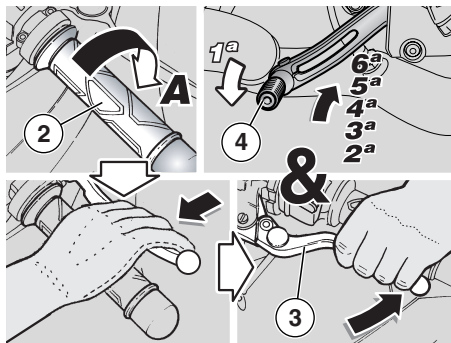

To shift down, proceed as follows:

- ◆ Release the throttle grip (2) (Pos.A).
- ◆ If necessary, apply the brakes moderately and slow down.
- ◆ Pull the clutch lever (3) and push down the gearshift lever (4) to shift down.
- ◆ If you have pulled the brakes, release them.
- ◆ Release the clutch lever and accelerate moderately.

⚠ CAUTION

If the alarm LED "⚠" and the "⚠ SERVICE" diagnosis icon come on during engine normal operation, it means that the control unit has detected a failure. In most cases, the engine will keep running, although giving less performance. Immediately contact a **Moto Guzzi** Authorized Dealer.

When the vehicle is at standstill with the engine running, avoid keeping the clutch pulled with a gear engaged for a long time or the clutch will overheat.

⚠ WARNING

Avoid opening and closing the throttle repeatedly and continuously, or you may lose control of the vehicle. When you need to brake, close the throttle and use both brakes for smooth braking; take care to apply the right amount of pressure to both brakes.

Using one brake only gives less braking power and you could lock a wheel and lose grip.

To stop uphill, decelerate completely and use the brakes to keep the vehicle at standstill.

Do not use engine braking or the clutch may overheat.

When approaching a turn, slow down or brake and take the turn at a moderate, constant speed or accelerate slightly; braking in a turn will greatly increase your chances of skidding.

Continued application of the brakes on long downhill grades may cause the brakes to overheat, thereby reducing braking efficiency. Shift down to use engine braking and apply both brakes intermittently.

Never ride downhill with the engine off!

If the road surface is wet or slippery (snow, ice, mud, etc.), ride slowly, do not brake or swerve suddenly, or you may lose grip and fall.

WARNING

Watch out for obstacles or sudden changes in the road surface.

Rough roads, rails, manhole covers, road markings, large steel plates near roadwork become slippery in the wet and should be avoided or negotiated with the greatest care, riding carefully and keeping the vehicle upright.

Signal your intention to change lane or turn in good time using the turn indicators and avoid sudden swerving or movements.

Switch off the turn indicators as soon as you have finished turning.

Be extremely careful when passing or being passed.

When riding in the rain, the spray thrown up by the tires of large vehicles will reduce your vision; the air wave created by a large vehicle may make you lose control of the vehicle.

RUNNING-IN

Correct engine running-in is essential to ensuring proper performance and durability.

Twisty, hilly roads are ideal for an effective running-in of engine, suspension and brakes.

Vary speed frequently during the running-in period.

This will allow engine parts to be alternately loaded and unloaded, allowing them to cool down when unloaded.

NOTE During the initial period of use, the clutch might give off a slight burning smell. This is perfectly normal, it will no longer smell as soon as the clutch plates run in.

While it is important to put some stress on engine components during running-in, it is equally important to avoid extreme load conditions.

NOTE From 1250 mi (2000 km) onward, the engine is ready to provide top performance.

Follow these recommendations:

- ◆ Do not flip the throttle open abruptly with the engine running at low rpm - either during or after the running-in period.
- ◆ Until you have covered the first 62 mi (100 km), use the brakes gently and avoid harsh, prolonged braking. This will help the brake pads bed in properly against the brake disks.

- ◆ During the first 930 mi (1500 km) never exceed 5000 rpm.

⚠ WARNING

After the first 930 mi (1500 km), have a **Moto Guzzi Authorized Dealer** carry out the "Post Running-In" checks specified in the periodic maintenance chart, see 72 (SCHEDULED MAINTENANCE CHART). Failure to perform these checks may lead to injury to yourself or other people and/or vehicle damage.

- ◆ After the first 930 mi (1500 km) and until 1250 mi (2000 km), ride more briskly, varying speed and using maximum acceleration for just a few seconds. This is to ensure better coupling of the components; never exceed 6000 rpm (see table).
- ◆ After the first 1250 mi (2000 km) you may run the engine harder, however, without exceeding the maximum rpm allowed (7600 rpm).

Recommended maximum engine rpm	
Distance covered mi (km)	rpm
0 – 930 (0 – 1500)	5000
930 – 1250 (1500 – 2000)	6000
over 1250 (2000)	7600

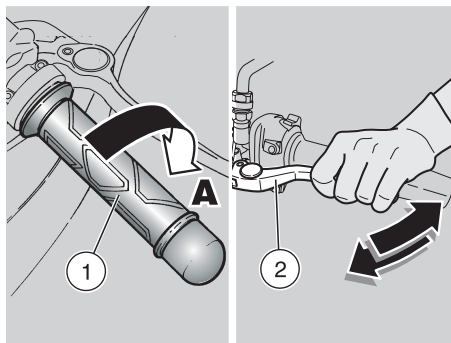

STOPPING

⚠ WARNING

If you can, do not stop or slow down suddenly and avoid limit-braking.

- ◆ Release the throttle grip (1) (pos. A) and gradually put on the brakes and shift down the gears at the same time to slow down, see page 65 (MOVING OFF AND RIDING).

When you have slowed down, before the vehicle comes to a stop:

- ◆ Pull the clutch lever (2) to prevent the engine stalling. When the vehicle has come to a stop:
- ◆ Select neutral (green warning light "N" on).
- ◆ Release the clutch lever (2).
- ◆ If you need to stop only briefly, keep at least one brake applied.

PARKING

It is very important to select an adequate place to park your vehicle - observe local regulations and the indications given below.

⚠ WARNING

Park the vehicle on firm and level ground to prevent it from falling.

Do not lean the vehicle against a wall, or lay it on the ground.

Make sure that the vehicle and any of its parts that are still hot do not pose a burn risk for any persons nearby, especially children. Do not leave the vehicle unattended with the engine running or the key in the ignition switch.

⚠ WARNING

Leaning the vehicle too far over or tipping it over may cause fuel to spill out of the tank.

The fuel used in internal combustion engines is highly flammable and can become explosive under particular conditions.

⚠ CAUTION

Do not rest your (and your passenger's) weight on the side stand.

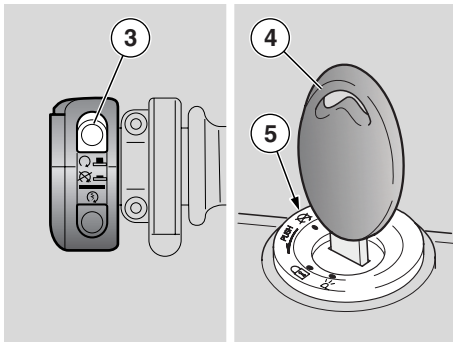

To park the vehicle:

- ◆ Select a suitable area for parking.
- ◆ Stop the vehicle, see in this page (STOPPING).
- ◆ Set the engine stop switch (3) to position "X".
- ◆ Turn the key (4) and set the ignition switch (5) to position "X".

⚠ WARNING

Carefully follow the indications for getting on and off the vehicle, see page 59 (GETTING ON AND OFF THE VEHICLE).

- ◆ Following the instructions, direct your passenger (if you are carrying one) to dismount and then get off.
- ◆ Lock the steering, see page 41 (STEERING LOCK) and remove the key (4).

⚠ WARNING

Make sure that the vehicle is stable.



PUTTING THE VEHICLE ON THE STAND

Side stand

To put the vehicle on the side stand while seated astride the vehicle, see page 59 (GETTING ON AND OFF THE VEHICLE).

If you have folded up the stand (say, to wheel the vehicle forward or backward), put the vehicle back on the stand as follows:

⚠ WARNING

Make sure the ground is firm and level and free from obstacles.

- ◆ Select an appropriate location for parking, see page 69 (PARKING).
- ◆ Grasp the left grip (1) and place your right hand on the rear upper part of the vehicle (2).

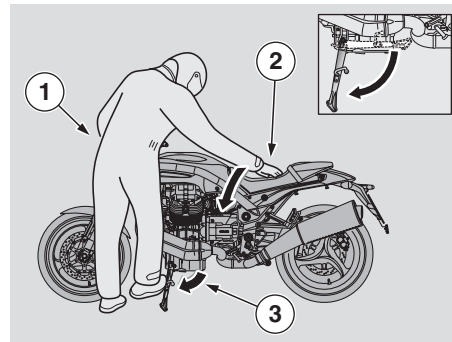

- ◆ Push on the side stand with your right foot and lower it completely (3).
- ◆ Lean the vehicle to the side until the stand is resting on the ground.
- ◆ Rotate the handlebar fully to the left.

⚠ WARNING

Make sure that the vehicle is stable.

SUGGESTIONS TO PREVENT THEFT

CAUTION

When a disk lock is used, remember to remove it before moving off. Failure to heed this warning can seriously damage the braking system and lead to an accident thus provoking serious injuries or death.

NEVER leave the key in the ignition switch and always use the steering lock. Park the vehicle in a safe place, possibly in a garage or at a guarded parking place. When possible, use an additional anti-theft device.

Make sure you have all the necessary documents with you and that the excise tax has been paid. Write your personal data and telephone number in this page to help trace the vehicle back to you in the event it is stolen and subsequently recovered.

LAST NAME:

FIRST NAME:

ADDRESS:

.....

TELEPHONE NO.:

NOTE Recovered vehicles are often traced back to the owner thanks to his/her details recorded in the Owner's Manual.

MAINTENANCE

WARNING

Fire hazard.

Keep fuel and other flammable substances away from electric components.

Before proceeding to service or inspect of the vehicle, stop the engine and remove the key from the ignition, wait for the engine and the exhaust system to cool down and, if possible, lift the vehicle using adequate lifting equipment placed on firm and level ground.

Ensure the area is well ventilated before proceeding.

Be careful not to touch hot engine and exhaust system parts that might burn you.

Do not put any vehicle parts into your mouth: vehicle components are not edible and some of them are harmful or even toxic.

CAUTION

Unless expressly indicated otherwise, reassembly is a reversal of the disassembly procedure.

Wear latex gloves during servicing.

Normally, scheduled maintenance can be carried out by the owner, although some operations may require specific tools and technical training.

For periodic maintenance, servicing or technical advice, contact a **Moto Guzzi**

Authorized Dealer, who will ensure prompt, accurate service.

Ask your **Moto Guzzi** Authorized Dealer to carry out a road test after a repair or scheduled maintenance operation.

In addition, perform the "Pre-ride checks" after each maintenance operation, see page 62 (PRE-RIDE CHECKS CHART).

NOTE This vehicle is equipped with an electronic engine control unit capable of detecting abnormal operation in real time and storing faults.

Any time the ignition switch is set to "○", the light "△" on the instrument panel comes on for three seconds.

CAUTION

If the alarm LED "△" and the "△ SERVICE" diagnosis icon come on during engine normal operation, it means that the control unit has detected a failure. In most cases, the engine will keep running, although giving less performance. Immediately contact a **Moto Guzzi** Authorized Dealer.

SCHEDULED MAINTENANCE CHART

OPERATIONS TO BE PERFORMED BY THE **Moto Guzzi** Authorized Dealer (CAN ALSO BE PERFORMED BY THE OWNER).

Component	End of running-in [930 mi (1500 km)]	Every 6250 mi (10000 km) or 12 months	Every 12500 mi (20000 km) or 24 months
Outer spark plugs (*)		③	
Engine oil filter (*)	③	③	
Fork	①		①
Light operation/beam setting		①	
Lighting system	①	①	
Safety switches			
Brake fluid		①	
Engine oil	③	③	
Tires	①	①	
Tire pressures (**)	④	④	
Battery terminals tightening	①		
Head bolts tightening	④		
Engine oil pressure warning light	at every start-up: ①		
Brake pad wear	①	before each ride and every 1250 mi (2000 km): ①	
Empty oil drain hose from air box	every 3125 mi (5000 km): ②		

① = check and clean, adjust, lubricate or change, if necessary; ② = clean; ③ = change; ④ = adjust.

Perform maintenance operations more frequently than the indicated intervals if you are riding in rainy or dusty conditions, on rough road surfaces or when the vehicle is used for racing.

(*) = If vehicle is used in competitions, change every 3125 mi (5000 km).

(**) = Check every two weeks or at the specified intervals.

OPERATIONS TO BE PERFORMED BY THE Moto Guzzi Authorized Dealer.

Component	End of running-in [930 mi (1500 km)]	Every 6250 mi (10000 km) or 12 months	Every 12500 mi (20000 km) or 24 months
Gearbox fluid	③	④	③
Idle mixture (CO)		①	
Bowden cables and controls	①	①	
Steering bearings and steering play	①	①	
Wheel bearings		①	
Brake disks	①	①	
Air filter		①	③
Vehicle operation	①	①	
Brake systems	①	①	
Brake fluid			③
Fork fluid	after the first 6250 mi (10000 km) and then every 12500 mi (20000 km):③		
Fork oil seals	after the first 18750 mi (30000 km) and then every 12500 mi (20000 km):③		
Brake pads	every 1250 mi/2000 km: ① - if worn: ③		
Valve clearance adjustment	④	④	
Wheels / tires	①	①	
Nut, bolt, screw tightening			
Battery terminals tightening	①		
Cylinder synchronization	①	①	
Suspensions and trim	①		①

① = check and clean, adjust, lubricate or change, if necessary (as specified in the Workshop Manual); ② = clean; ③= change; ④= adjust.

Halve maintenance intervals if you are riding in rainy or dusty conditions, on rough road surfaces or when the vehicle is used for racing.

(*) = If vehicle is used for racing, check every 3125 mi (5000 km).

Component	End of running-in [930 mi (1500 km)]	Every 6250 mi (10000 km) or 12 months	Every 12500 mi (20000 km) or 24 months
Final transmission fluid	③	④	③
Fuel pipes		①	every 4 years:③
Brake lines		①	every 4 years:③
Clutch wear (*)		①	
Inner spark plugs			③
Generator belt		every 12500 mi (20000 km): ④, every 31250 mi (50000 km): ③	
Head stud bolts tightening	④		
Exhaust pipe flanges bolts	①		
<p>① = check and clean, adjust, lubricate or change, if necessary (as specified in the Workshop Manual); ② = clean; ③= change; ④= adjust. Halve maintenance intervals if you are riding in rainy or dusty conditions, on rough road surfaces or when the vehicle is used for racing. (*) = If vehicle is used for racing, check every 3125 mi (5000 km).</p>			

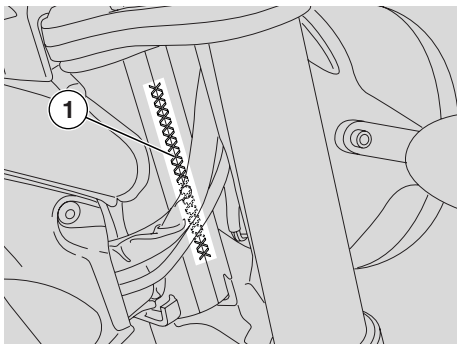

IDENTIFICATION DATA

It is a good rule to report the frame and engine numbers in the space provided in this manual.

The frame number must be quoted when purchasing spare parts.

NOTE Altering a vehicle identification numbers is illegal and punished by law with fines and imprisonment. In addition, altering the frame number invalidates the warranty.

FRAME NUMBER

The frame number (1) is stamped on the right side of the steering tube.

Frame no. _____

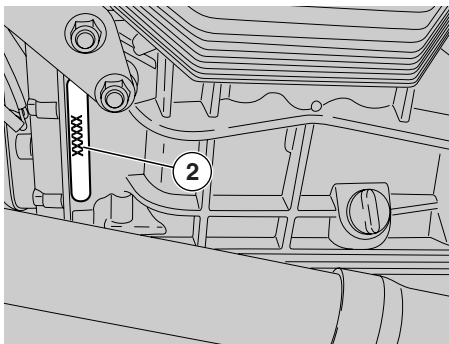

ENGINE NUMBER

The engine number (2) is stamped on the left side close to the oil level plug/dipstick.

Engine no. _____

JOINTS WITH SCREW CLAMPS

⚠ CAUTION

Remove **ONLY** the clamps indicated in the maintenance procedures.

This text is not to be intended as an authorisation to arbitrarily remove the clamps present on the vehicle.

⚠ WARNING

Before removing a clamp, determine whether removal may lead to leakage and, if so, take adequate measures to prevent leakage and protect the components positioned near the joint.

SCREW CLAMPS

For removal and installation it is sufficient to use a common screwdriver.

⚠ CAUTION

Check the conditions of the clamp and if necessary replace it with a new one of the same type and dimensions, available on request from **Moto Guzzi** Authorized Dealers.

When tightening the clamp, make sure that the joint is sufficiently stable.

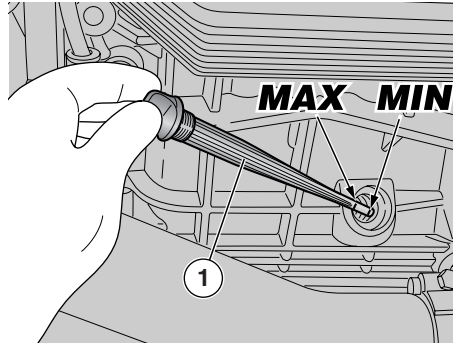
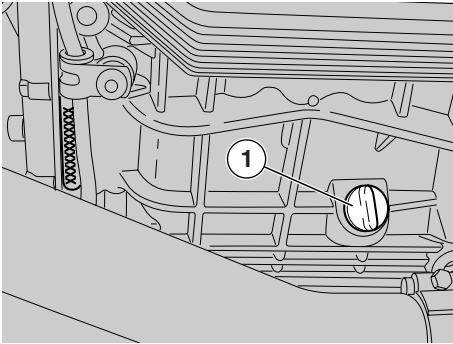

CHECKING AND TOPPING UP ENGINE OIL LEVEL

Carefully read page 56 (ENGINE OIL) and page 71 (MAINTENANCE).

NOTE Halve maintenance intervals if you are riding in rainy or dusty conditions, or on rough road surfaces.

Periodically check engine oil level, change the oil every 6250 mi (10000 km), see page 76 (CHECKING AND TOPPING UP ENGINE OIL LEVEL)

⚠ WARNING

It is critical to the safe operation of your vehicle that the proper lubricants, maintained at the proper levels, are used. Failure to heed this warning can lead to an engine seizure with subsequent accident, serious injury or death.

Check as follows:

NOTE Place the vehicle on firm and flat ground.

⚠ CAUTION

The engine oil level must be checked with a warm engine and with the oil level dipstick (1) not tightened.

If you check level when the engine is cold, oil level may have temporarily dropped below the "MIN" mark.

This is not a problem, provided that the alarm light "⚠" and the engine oil pressure icon "🛢" do not come on, see page 31 (INSTRUMENTS AND INDICATORS TABLE).

NOTE Letting the engine idle with the vehicle at standstill is not the correct procedure to warm engine and engine oil up to operating temperature for an oil

check. Oil is best checked after a trip or after traveling approximately 10 mi (15 km) out of town (this is sufficient to bring engine oil up to operating temperature).

⚠ WARNING

Exhaust gases contain carbon monoxide, which is extremely poisonous if inhaled. Do not start the engine in closed or badly-ventilated rooms. Failure to observe this warning may cause loss of consciousness or even lead to death by asphyxia.

- ◆ Stop the engine, see page 63 (STARTING).
- ◆ Keep the vehicle in vertical position, the two wheels resting on the ground.

⚠ WARNING

Should your vehicle overturn, it will leak gasoline, which is extremely flammable. Flames or sparks may cause a fire, which could destroy not only the vehicle, but also the building in which it is located, and cause serious injuries or even death.

- ◆ Undo the filler plug/oil dipstick (1).
- ◆ Clean the oil dipstick (1) and refit, do not tighten.
- ◆ Take it out again and check oil level.
- ◆ Correct level is achieved when the oil is just below the **MAX** level mark.

⚠ CAUTION

Never exceed the "MAX" mark or let oil level drop below the "MIN" mark, as this may lead to severe engine damage.

If necessary, top up engine oil level as follows:

- ◆ Unscrew and remove the filler plug (1).

CAUTION

When warm, the engine contains hot oil and the oil tank is warm; therefore take extreme care in performing the operations described below to avoid burns.

CAUTION

Before unscrewing and removing the filler cap, clean it and the area of the tank around it with a clean cloth. Prevent any foreign matter from falling into the oil tank, this could cause serious engine damage.

Do not use any flammable solvents such as alcohol or gasoline when wiping the oil tank. The oil tank is hot enough to cause ignition of flammable solvents.

Use only a natural fiber cloth, such as cotton. Man made fabrics such as polyester, etc. may ignite.

CAUTION

Use thick gloves to prevent burns.

CAUTION

Do not add any additives or other products to the oil.

If you use a funnel or other tools, make

sure that they are perfectly clean.

NOTE Use high-quality 5W - 40 oil, see page 106 (LUBRICANT CHART).

Top up to correct level, see page 106 (LUBRICANT CHART).

WARNING

Never ride your vehicle with low engine oil, or with contaminated oil, or with unapproved oil. Any of these will greatly accelerate wear of your engine, and cause irreparable damage.

FRONT WHEEL

CAUTION

Disassembling and reassembling the front wheel may prove difficult; these operations are best left to experienced mechanics.

If necessary, contact a **Moto Guzzi** Authorized Dealer.

WARNING

Riding with damaged rims may be dangerous for the rider, other persons and the vehicle.

Check the conditions of the wheel rim and change it if damaged.

REAR WHEEL

⚠ CAUTION

Disassembling and reassembling the rear wheel may prove difficult; these operations are best left to experienced mechanics.

If necessary, contact a **Moto Guzzi** Authorized Dealer.

⚠ WARNING

Riding with damaged rims may be dangerous for the rider, other persons and the vehicle.

Check the conditions of the wheel rim and change it if damaged.

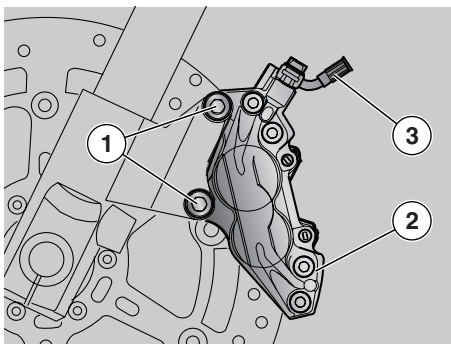

FRONT BRAKE CALIPER

⚠ WARNING

The disassembly and reassembly of the front brake calipers can be difficult for those unfamiliar with vehicle maintenance. You may wish to have your Local **Moto Guzzi** Dealer carry out these operations.

If you wish to perform these operations yourself, read p. 71 (MAINTENANCE) carefully.

⚠ WARNING

A dirty disk will soil the pads, leading to loss of braking efficiency. Dirty pads must be replaced, while dirty disks must be cleaned with a high-quality degreaser.

⚠ CAUTION

When disassembling and reassembling, be careful not to damage the brake hoses, the disks and the pads.

NOTE To remove the front brake caliper, the vehicle must be kept upright and safely supported, with the front wheel raised off the ground.

DISASSEMBLY

CAUTION

Make sure that the vehicle is stable.

- ◆ Rotate the wheel manually until bringing the space between two wheel spokes before the brake caliper.
- ◆ Have someone keep the handlebar steady in a position as for riding, so that the steering is locked.

Brake caliper screws (1) tightening torque: 50 Nm (5 kgm).

- ◆ Unscrew and remove the two brake caliper screws (1).

CAUTION

Do not operate the brake lever after removing the caliper, otherwise the pistons may slip out of their seats, leading to brake fluid leakage.

Should this happen, contact your **Moto Guzzi Authorized Dealer, who will rectify the problem.**

- ◆ Withdraw the brake caliper (2) from the disk, leaving it attached to the hose (3).

REASSEMBLY

CAUTION

Proceed with care, in order not to damage the brake pads.

WARNING

Keep your fingers free. Avoid getting them caught between the wheel, the caliper or the fork. Do not attempt to align the holes in the caliper using your fingers. Failure to obey this warning can lead to serious injury.

- ◆ Position the brake caliper (2) to the disk so that the caliper mounting holes match the support holes.

WARNING

On assembly, replace both caliper retaining screws (1) with new ones of the same type.

- ◆ Screw and tighten the two caliper retaining screws (1).

Brake caliper screws tightening torque: 50 Nm (5 kgm).

WARNING

After servicing the brakes, always check that they operate correctly. If the stroke of the lever or pedal is excessive, or if you detect that the effectiveness of the brakes is reduced in any way, have your vehicle serviced by your **Local Moto Guzzi Dealer**. It may be necessary to have your dealer bleed the system, or there may be some other problem with the brake system.

Never ride your vehicle in traffic immediately after servicing the brakes. Always apply the brake pedal or lever several times before riding your vehicle. Then, try your vehicle in a parking lot or other safe area with little traffic to ensure that the brakes are working properly. Failure to observe this warning can lead to a serious accident with subsequent serious injury or even death.

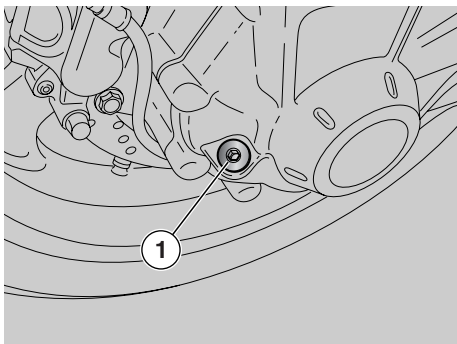

CHECKING THE CARDAN SHAFT OIL LEVEL

NOTE Halve maintenance intervals if you are riding in rainy or dusty conditions, or on rough road surfaces.

Check cardan shaft oil level at regular intervals; change the oil after the first 930 mi (1500 km) and then every 12500 mi (20,000 km) thereafter.

Check as follows:

- ◆ Keep the vehicle in vertical position, with the two wheels resting on the ground.
- ◆ Undo and remove the level plug (1).
- ◆ Check that oil level is just below the hole for the level plug (1). Top up if oil is below the specified level.

To top up or change cardan shaft oil, contact a **Moto Guzzi** Authorized Dealer.

CHECKING GEARBOX FLUID LEVEL

- ◆ To check, top up and change gearbox oil, contact a **Moto Guzzi** Authorized Dealer.

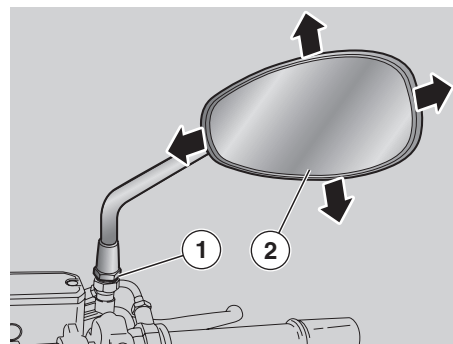

REARVIEW MIRRORS

⚠ WARNING

Do not ride with rearview mirrors incorrectly set.

Before leaving, always ensure they are correctly set.

⚠ WARNING

Wear clean gloves or use a clean cloth to adjust rearview mirrors position to keep the reflecting surface clean, and ensure proper visibility.

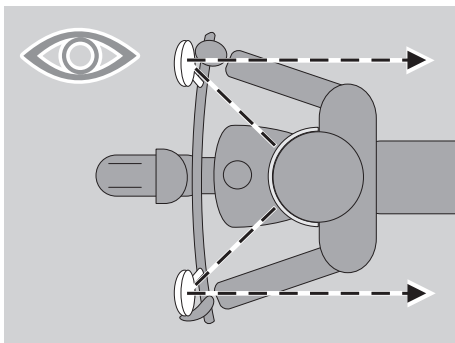

Setting the rearview mirrors

- ◆ Sit astride the vehicle, see page 59 (GETTING ON AND OFF THE VEHICLE).

⚠ CAUTION

Handle parts with care.

- ◆ Turn mirror (2) and set correct slant. Repeat the procedure to set the other mirror.
- ◆ Ensure there are no dirty residues.

REMOVING THE REARVIEW MIRRORS

- ◆ Place the vehicle on the stand, see page 70 (PUTTING THE VEHICLE ON THE STAND).
- ◆ Loosen the locknut (1).

⚠ CAUTION

On reassembly, before tightening nut (1), ensure that the mirror support rod is correctly positioned in line with the handlebar.

- ◆ Slide up and remove the complete rearview mirror unit.

Repeat the procedure to remove the other mirror, if necessary.

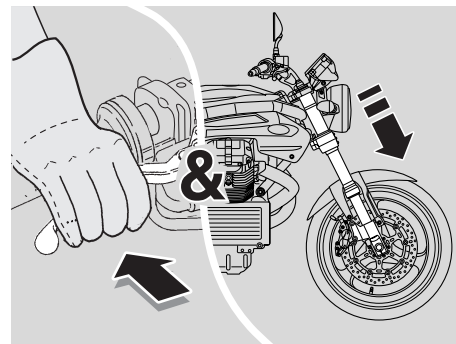

INSPECTING THE FRONT AND REAR SUSPENSIONS

Carefully read page 71 (MAINTENANCE).

NOTE Have the front fork oil changed by a **Moto Guzzi** Authorized Dealer, who will ensure prompt, accurate service.

NOTE Halve maintenance intervals if you are riding in rainy or dusty conditions, on rough road surfaces or when the vehicle is used in competitions.

Have the front fork oil changed after the first 6250 mi (10000 km) and then every 12500 mi (20000 km).

Perform the following checks after the first 930 mi (1500 km) and every 6250 mi (10,000 km) afterwards:

- ◆ Keep the front brake lever pulled in and push down on the handlebar repeatedly to compress the front fork. The fork should compress in a smooth movement and must show no traces of oil on the legs.
- ◆ Ensure that all components are properly tightened and check the front and rear suspension articulated joints for correct operation.

⚠ CAUTION

In the event of faulty operation or if you need qualified assistance, contact your **Moto Guzzi** Authorized Dealer.

FRONT SUSPENSION

- ◆ Have the fork oil seals changed by a **Moto Guzzi** Authorized Dealer after the first 18,750 mi (30,000 km) and then every 12,500 mi (20,000 km).

REAR SUSPENSION

The rear suspension consists of a spring-shock absorber unit, fixed to the frame by means of a silent block and to the swinging arm by means of lever systems.

For setting adjustments, the shock absorber has

- an adjuster (1) for rebound hydraulic damping;
- an adjuster (2) for compression hydraulic damping;
- an adjusting ring nut (3) and a locking ring nut (4) for the adjustment of the spring preload.

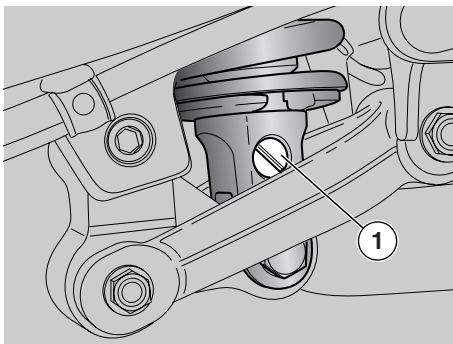

ADJUSTING THE REAR SHOCK ABSORBER

NOTE Halve maintenance intervals if you are riding in rainy or dusty conditions, on rough road surfaces or when the vehicle is used in competitions.

Check the rear shock absorber every 10000 km (6250 mi) and adjust as required.

The standard setting of the rear shock absorber is adjusted so that it is suitable for most driving conditions (low and high speed).

However, suspension setting may be modified to suit specific needs in accordance with vehicle use.

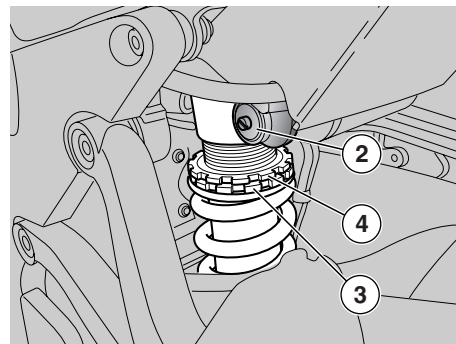

⚠ WARNING

Allow the engine and silencer to cool down before working the adjusters.

⚠ CAUTION

Before adjusting, first set the rear shock absorber to the stiffest setting [turn the adjusters (1-2) fully clockwise]. Do not force the adjusters (1-2) beyond their limit stops in either direction, or the threads may strip.

- ◆ Use the special spanner available at **Moto Guzzi** Authorized Dealer and unscrew the locking ring nut (4).
- ◆ Adjust spring preload (A) through the adjusting ring nut (3) (see table).

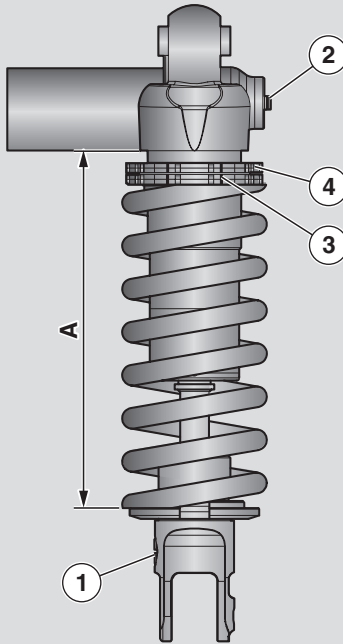

- ◆ After adjusting, tighten the ring nut (4).
- ◆ Work the screw (1) to set shock absorber rebound damping (see table).
- ◆ Work the screw (2) to set shock absorber compression damping (see table).

⚠ CAUTION

Set spring preload and rebound damping according to vehicle usage.
 When you increase spring preload, you will have to increase rebound damping accordingly to avoid unexpected jerking when riding.
 If necessary, contact your **Moto Guzzi** Authorized Dealer.

⚠ WARNING

Racing settings may only be used during official competitions or sports events authorised by the competent authorities and taking place in closed circuits or, anyway, away from public roads.

It is strictly prohibited to carry out adjustments for the use of the vehicle on racetracks and then ride it on roads or highways.

Settings	Setting the rear suspension	Setting the front fork
Spring length (preloaded) (A)	161	5 notches
Rebound adjustment, ring nut (1)	Tighten fully (*) and then slacken (**) by 17 click positions	Tighten fully (*) and then slacken (**) by 1.5 turns
Compression damping, screw (2)	Tighten fully (*) and then slacken (**) by 1.5 turns	Tighten fully (*) and then slacken (**) by 1 turn

(*) = clockwise

(**) = counterclockwise

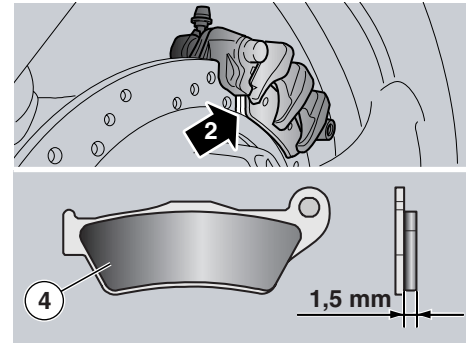
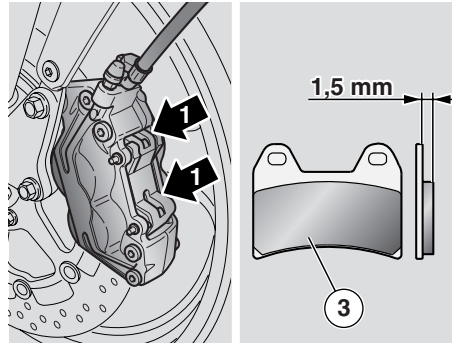
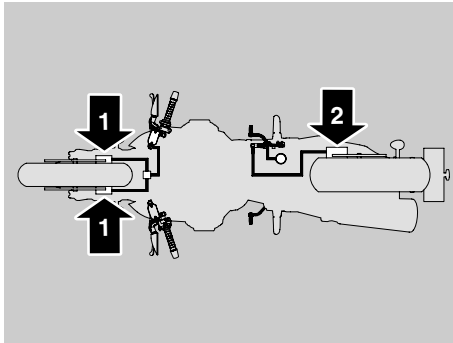

CHECKING THE BRAKE PADS FOR WEAR

Carefully read page 48 (BRAKES), page 49 (DISK BRAKES) and page 71 (MAINTENANCE).

NOTE The following information applies to both braking systems.

NOTE Halve maintenance intervals if you are riding in rainy or dusty conditions, on rough road surfaces or when the vehicle is used in competitions.

Check the brake pads for wear after the first 930 mi (1500 km), every 1250 mi (2000 km) afterwards and before each ride.

The rate at which brake pads will wear depends on vehicle usage, riding style and road surface condition.

⚠ WARNING

Check the brake pads for wear, possibly before each ride.

Outlined below is a quick brake pad inspection procedure:

- ◆ Place the vehicle on the stand, see page 70 (PUTTING THE VEHICLE ON THE STAND).
- ◆ Visually inspect the area between brake disk and brake pads proceeding as follows:
 - look from above at the rear to check the front brake caliper (1);
 - on vehicle opposite side, through the rim, to check the rear brake caliper (2).

⚠ WARNING

If brake pads were allowed to wear down to the metal substrate, metal-to-metal contact with the brake disk would lead to rattling and the brake caliper sparking; this would result in loss of braking and brake disk damage, leading to a dangerous riding condition.

When the lining material of any one of the brake pads [whether front (3) or rear (4)] is worn down to nearly 1.5 mm, or when one of the wear indicators is worn away, have all brake pads changed.

⚠ WARNING

To have them replaced, contact your **Moto Guzzi Authorized Dealer**.

ADJUSTING THE THROTTLE CONTROL

Carefully read page 71 (MAINTENANCE).

⚠ WARNING

If the throttle sticks open, it may cause a collision with another vehicle or an accident. If the throttle sticks, kill the engine with the engine stop switch located on the right handlebar. Do not attempt to restart the engine until the throttle has been repaired and works perfectly. Failure to obey this warning can lead to a runaway resulting in serious injury or even death. If any fastener in the throttle system becomes loose, you will lose control of your vehicle. Either situation can lead to an accident or collision with subsequent serious injury or death.

⚠ WARNING

In the event of a throttle sticking emergency, always kill the engine using the engine stop switch located near the throttle grip on the right handlebar. Never use your vehicle if the throttle does not automatically fully return to the idle position when the throttle grip is released. Contact your Local **Moto Guzzi** Dealer for repairs. Failure to heed this warning can lead to a serious accident and subsequent injury or even death.

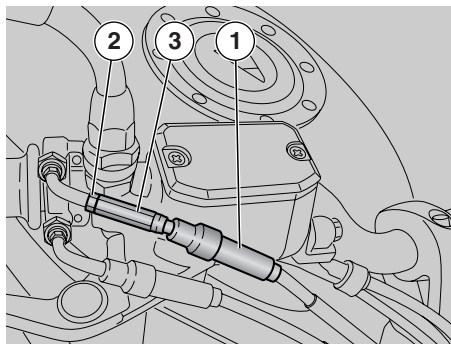

NOTE Halve maintenance intervals if you are riding in rainy or dusty conditions, on rough road surfaces or when the vehicle is used in competitions.

Have the throttle control cables checked by a **Moto Guzzi** Authorized Dealer after the first 930 mi (1500 km) and then every 6250 mi (10000 km).

There should be **2-3** mm free play in the throttle twistgrip (measured at twistgrip edge).

If not so:

- ◆ Place the vehicle on the stand, see page 70 (PUTTING THE VEHICLE ON THE STAND).
- ◆ Withdraw the protection (1).
- ◆ Loosen the lock nut (2).
- ◆ Rotate the adjuster (3) until obtaining the specified free play.
- ◆ When finished, tighten the lock nut (2) and check free play again.
- ◆ Refit the protection (1).

⚠ WARNING

Exhaust gases contain carbon monoxide, which is extremely poisonous if inhaled.

Do not start the engine in closed or poorly-ventilated rooms. Failure to observe this warning may cause loss of consciousness or even lead to death by asphyxia.

⚠ CAUTION

When finished, turn the handlebar to make sure its movement does not affect the engine idle rpm and check that the throttle grip - when opened and then released - returns smoothly to the closed position.

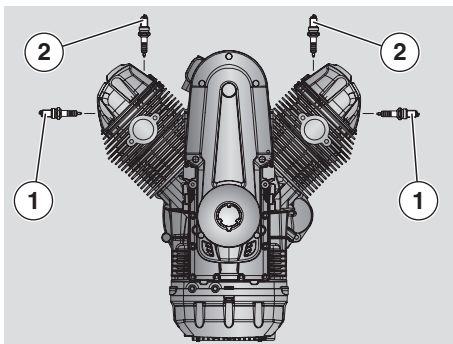

SPARK PLUGS

⚠ CAUTION

The following instructions apply only to outer spark plugs (1). This vehicle is also fitted with two inner spark plugs (2). Contact a **Moto Guzzi** Authorized Dealer to have them replaced.

Carefully read page 71 (MAINTENANCE).

NOTE Halve maintenance intervals if you are riding in rainy or dusty conditions, on rough road surfaces or when the vehicle is used in competitions.

⚠ CAUTION

Check, clean or replace the outer spark plugs (1), one at a time.

Change the outer spark plugs (1) every 6250 mi (10000 km).

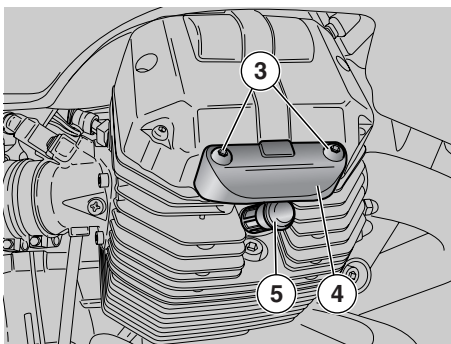

⚠ CAUTION

Even if only one outer spark plug (5) needs replacing, always change both.

⚠ WARNING

Before carrying out the following operations, let the engine and the silencer cool down until they reach room temperature, in order to avoid burns.

The following procedures apply to both cylinders.

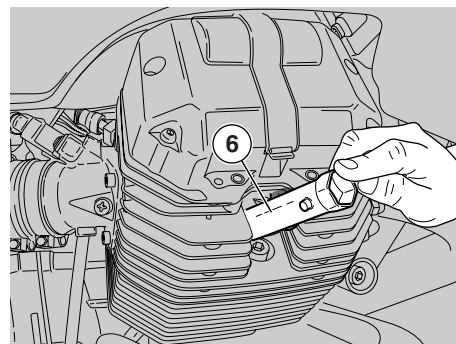

Removal:

- ◆ Release the two screws (3) and remove the retainer (4).
- ◆ Remove the spark plug cap (3).
- ◆ Remove any trace of dirt from the spark plug base.
- ◆ Introduce the special wrench provided in the tool kit on the spark plug.
- ◆ Insert the spanner (6) included in the tool kit into the hexagonal seat of the spark plug socket.
- ◆ Unscrew the spark plug and extract it from its seat, taking care to prevent dust or other substances from getting inside the cylinder.

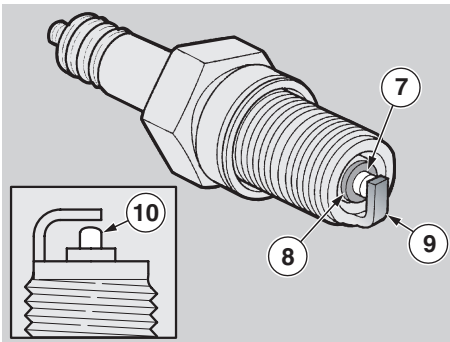

Inspection and cleaning:

⚠ CAUTION

Do not clean the spark plugs with a wire brush and/or abrasive products, use compressed air only.

Key:

- center electrode (7);
- insulator (8);
- side electrode (9).
- ◆ Check electrodes and insulator for carbon deposits or traces of corrosion and blow them with compressed air if needed.

Always change a spark plug which has a cracked insulator, corroded electrodes, excessive deposits or when the tip (10) of the central electrode (7) is rounded from wear.

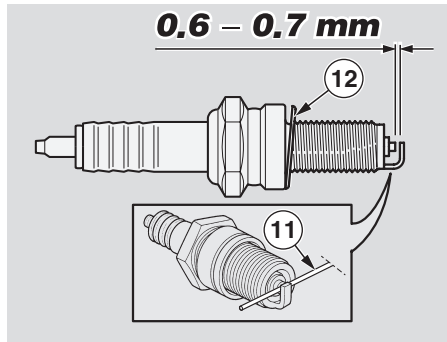

⚠ CAUTION

Only use recommended spark plugs, see page 103 (TECHNICAL DATA) or the engine performance and life-span might be impaired.

Electrode gap should be checked using a wire gauge (11) to avoid damaging the platinum coating.

- ◆ Check electrode gap with a wire gauge (11).

⚠ CAUTION

Never attempt to adjust electrode gap.

Electrode gap should be 0.6 - 0.7 mm. If not so, change the spark plug.

- ◆ Make sure that the washer (12) is in good condition.

Installation:

- ◆ Position the washer (12) and screw in the spark plug by hand in order not to damage the thread.
- ◆ Tighten each spark plug by one half of a turn to compress the washer using the socket included in the tool kit.

Spark plug tightening torque: 20 Nm (2 kgm).

⚠ CAUTION

The spark plug must be tightened firmly, otherwise the engine may overheat and severe damage may occur.

- ◆ Position the spark plug cap properly to prevent it coming off due to engine vibration.

NOTE Repeat the above procedure for the spark plug of the other cylinder.

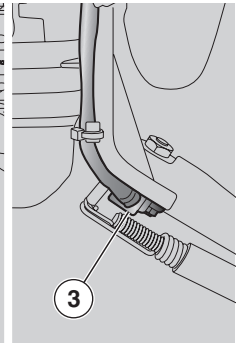
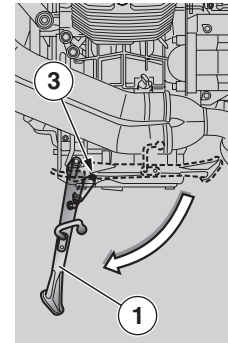
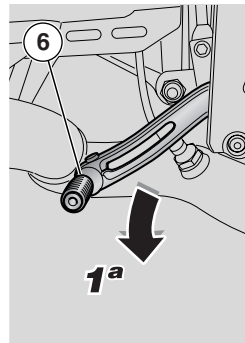
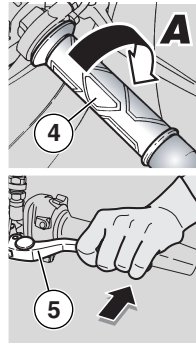
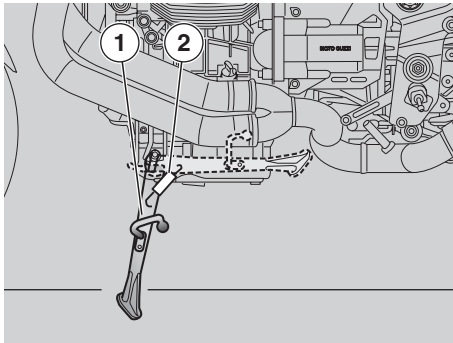

CHECKING THE STAND

Carefully read page 71 (MAINTENANCE) and page 92 ().

The vehicle is equipped with a stand:

– side stand (1).

The stand features two positions:

– standard or up (at rest);
– down.

Operation of the stand is the rider's responsibility.

The stand should turn smoothly.

The spring (2) keeps the stand in the desired position (extended or retracted).

SIDE STAND

- ◆ Place the vehicle on the stand, see page 50 (PUTTING THE VEHICLE ON THE STAND).
- ◆ Check the spring (2): it must not be damaged, worn, rusty or weakened.
- ◆ Make sure that the stand has no play in either position (extended and retracted).
- ◆ Lower the stand to make sure the springs let it extend completely.
- ◆ Pull the stand midway up and let go to make sure the springs let it retract completely.
- ◆ The stand should turn smoothly: smear the joint with grease, if necessary, see page 85 (LUBRICANT CHART).

The side stand (1) is equipped with a safety switch (3) that inhibits ignition or stops the engine whenever a gear is engaged while the side stand (1) is down.

To determine proper operation of the safety switch (3), proceed as follows:

- ◆ Sit astride the vehicle.
- ◆ Fold up the side stand (1).
- ◆ Start the engine, see page 43 (STARTING).
- ◆ With the throttle twistgrip (4) released (Pos. A), let engine idle and pull the clutch lever (5) fully in.
- ◆ Push down the gear change lever (6) to engage the first gear.
- ◆ Lower the side stand (1) to operate the safety switch (3).

The following occurs:

- the engine must stop;
- the side stand down LED "Z" on the instrument panel should come on.

⚠ CAUTION

If the engine keeps running, contact a **Moto Guzzi** Authorized Dealer.

BATTERY

Carefully read page 71 (MAINTENANCE).

⚠ WARNING

Fire hazard.

Keep fuel and other flammable substances away from electric components.

Never invert the battery cables.

Ensure that the ignition switch is in position "⊗" before connecting or disconnecting the battery, otherwise some components might damage.

Connect the positive cable (+) first and then the negative cable (-).
Disconnect in the reverse order.

NOTE This vehicle is fitted with a maintenance-free battery which seldom needs inspecting, but may need charging from time to time.

LONG INACTIVITY OF THE BATTERY

⚠ CAUTION

When the motorcycle is to be left unused for over twenty days, disconnect the 30-A fuses, otherwise the multifunction computer will keep drawing current and the battery will deteriorate.

NOTE Removing the 30A fuses resets the digital clock functions. To reset these functions, see page 33 (MULTIFUNCTION COMPUTER).

Should the vehicle be unused for more than fifteen days, it is necessary to charge the battery to avoid sulphation, see page 91 (CHARGING THE BATTERY).

- ◆ Remove the battery, see page 90 (REMOVING THE BATTERY) and arrange it in a cool and dry place.

To avoid degradation in the wintertime or while the vehicle is stored away, check battery charge at regular intervals (monthly).

- ◆ Recharge it completely, using a standard charge, see page 91 (CHARGING THE BATTERY).

If you are leaving the battery installed to the vehicle, disconnect the cables from the terminals.

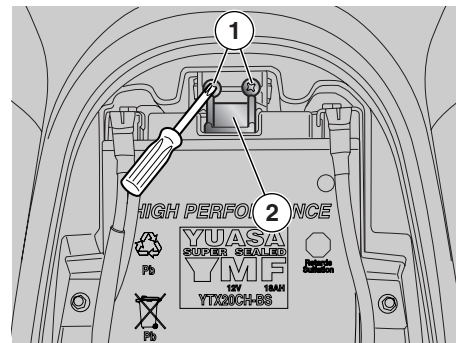

CHECKING AND CLEANING THE TERMINALS

Carefully read page 89 (BATTERY).

- ◆ Make sure that the ignition switch is in position "⊗".
- ◆ Remove the rider seat, see page 43 (UNLOCKING/LOCKING THE SEAT).
- ◆ Loosen the two screws (1) and move aside the cover (2).

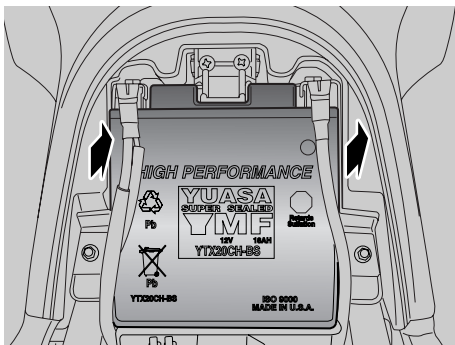

- ◆ Make sure that the cable terminals and the battery terminals are:
 - in good condition (and not corroded or covered with deposits);
 - covered with neutral grease or Vaseline.

If necessary:

- ◆ Remove the battery, see (REMOVING THE BATTERY), in this page.
- ◆ Clean off cable and battery terminals with a wire brush to remove all traces of corrosion.
- ◆ Install the battery, see page 92 (INSTALLING THE BATTERY).

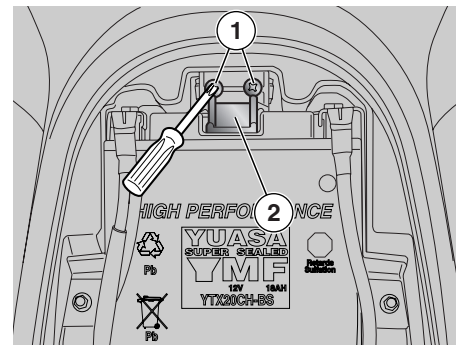

REMOVING THE BATTERY

⚠ CAUTION

Removing the battery resets the following functions: digital clock, trip info and lap times. To reset these functions, see page 33 (MULTIFUNCTION COMPUTER).

Carefully read page 89 (BATTERY).

- ◆ Make sure that the ignition switch is in position "⊗".
- ◆ Remove the rider seat, see page 43 (UNLOCKING/LOCKING THE SEAT).
- ◆ Loosen the two screws (1) and move aside the cover (2).

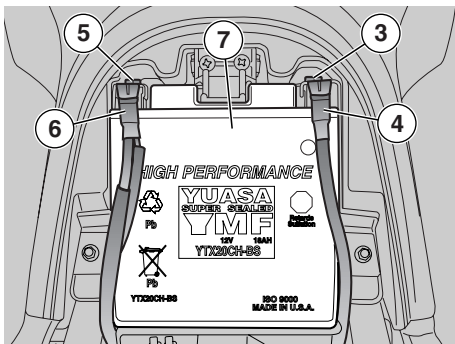

- ◆ Release and remove the negative (-) terminal screw (3).
- ◆ Move aside the negative cable (4).
- ◆ Release and remove the positive (+) terminal screw (5).
- ◆ Move aside the positive cable (6).
- ◆ Grasp the battery (7) firmly and lift it out of its compartment.

⚠ WARNING

Once removed, the battery must be stored in a safe place and kept away from children.

- ◆ Place the battery on a flat surface, in a cool and dry place.

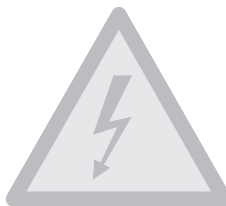

- ◆ Refit the rider seat, see page 92 (INSTALLING THE BATTERY).

NOTE For battery installation, see page 92 (INSTALLING THE BATTERY).

CHECKING BATTERY FLUID LEVEL

Carefully read page 89 (BATTERY).

This vehicle is fitted with a maintenance-free battery. It is not necessary to check battery fluid level.

CHARGING THE BATTERY

Carefully read page 89 (BATTERY).

- ◆ Remove the battery, see page 90 (REMOVING THE BATTERY).
- ◆ Be sure to have a suitable battery charger on hand.
- ◆ Set the battery charger to the required type of charge (see table).
- ◆ Connect the battery to the charger.

⚠ WARNING

Charge or use the battery in a well-ventilated place. Do not inhale the gas produced by the battery under charging.

- ◆ Switch the battery charger on.

Recharge	Electric current (Ampere)	Time (hours)
Standard	1.8	8 – 10

⚠ WARNING

The battery keeps producing gases for some time after the battery charger has been switched off. Allow 5-10 minutes before refitting the battery.

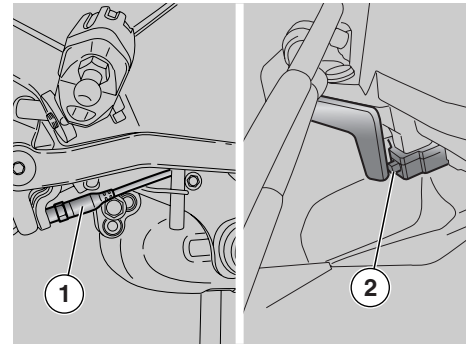
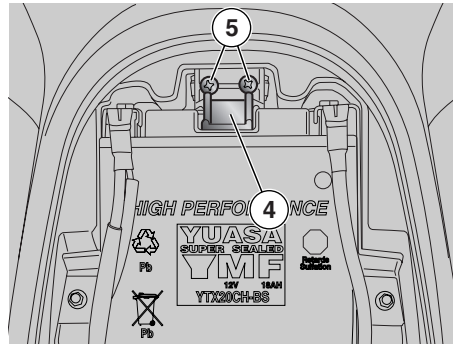
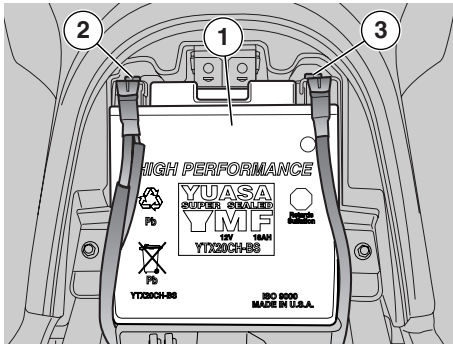

INSTALLING THE BATTERY

Carefully read **page 89 (BATTERY)**.

- ◆ Make sure that the ignition switch is in position "X".
- ◆ Remove the rider seat, see **page 43 (UNLOCKING/LOCKING THE SEAT)**.

NOTE The battery (1) should be positioned in its housing with the terminals facing the vehicle front end.

- ◆ Insert the battery (1) in its compartment.

⚠ WARNING

Upon reassembly, connect the positive cable (+) first and then the negative cable (-).

- ◆ Connect the positive (+) cable by tightening the terminal screw (2).
- ◆ Connect the negative (-) cable by tightening the terminal screw (3).
- ◆ Coat the terminals of cables and battery with neutral grease or Vaseline.
- ◆ Install the battery in the correct position, fully into its seat.
- ◆ Tighten the screws (5) to secure the cover (4).
- ◆ Refit the rider seat, see **page 43 (UNLOCKING/LOCKING THE SEAT)**.

⚠ CAUTION

Removing the battery resets the following functions: digital clock, trip info and lap times. To reset these functions, see **page 33 (MULTIFUNCTION COMPUTER)**.

CHECKING THE SWITCHES

Carefully read **page 71 (MAINTENANCE)**.

The vehicle is equipped with four switches:

- 1) Stop light switch on the rear brake control lever;
- 2) Stop light switch on the front brake control lever;
- 3) Safety switch on the side stand;
- 4) Switch on the clutch lever.

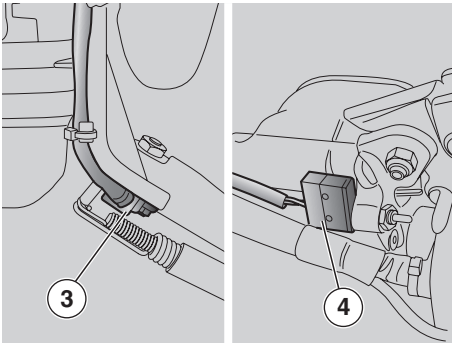

- ◆ Clean the switch if caked with dirt or mud. The pin must move freely and return automatically to its initial position.
- ◆ Make sure that the cables are connected correctly.

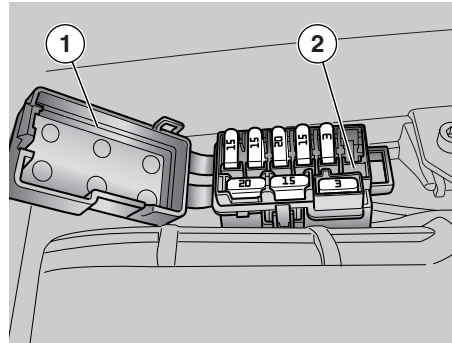

CHANGING THE FUSES

Carefully read page 71
(MAINTENANCE).

⚠ CAUTION

Do not repair faulty fuses.

Never use a fuse of a rating other than specified.

This could damage the electric system or cause a short circuit, with the fire hazard.

NOTE If a fuse blows repeatedly, there might be a short circuit or an overload in the electric system.

In this case it is advisable to contact a **Moto Guzzi** Authorized Dealer.

Checking the fuses is recommended whenever an electric component fails to operate or is malfunctioning, or when the engine does not start.

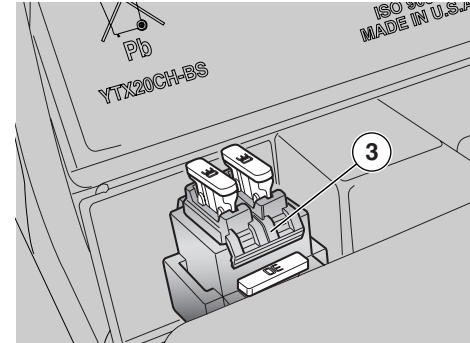

First check the auxiliary fuses (2), then the main fuses (3).

Check as follows:

- ◆ Set the ignition switch to "⊗" to avoid an accidental short circuit.
- ◆ Remove the rider seat, see page 43 (UNLOCKING/LOCKING THE SEAT).
- ◆ Open the auxiliary fuses (2) carrier (1) cover.
- ◆ Extract and check the fuses one by one - a divided link bar (4) means that the fuse is blown.
- ◆ Before replacing a fuse, identify the cause of the failure if possible.
- ◆ Replace the blown fuse with a new one with equal current rating.

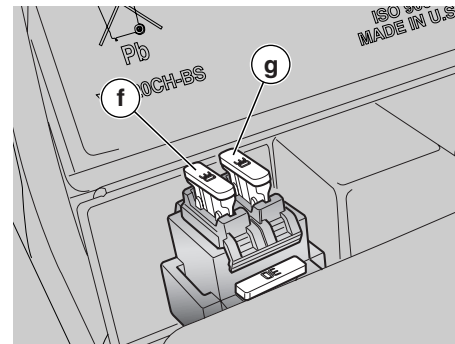
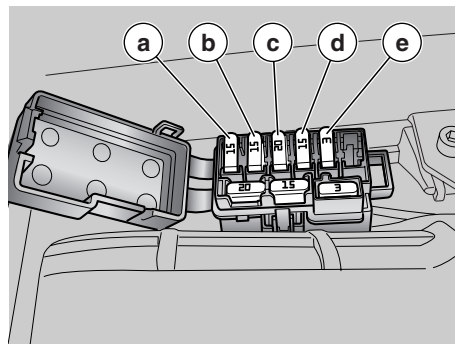
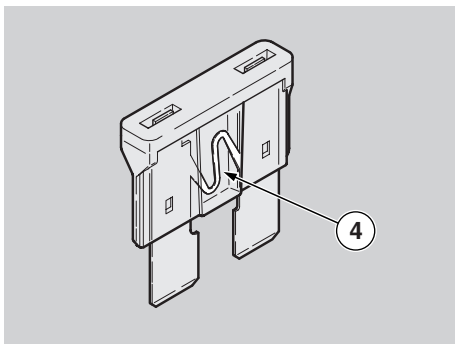

NOTE When you use one of the spare fuses, remember to add a new spare fuse into the proper seat.

◆ Repeat the above operations for the main fuses.

NOTE Removing the 30A fuses resets the following functions: digital clock, trip info and lap times.

To reset these functions, see page 33 (MULTIFUNCTION COMPUTER).

ARRANGEMENT OF AUXILIARY FUSES

- a) Stop, horn, HAZARD button light, light relay coil (15A).
- b) Parking lights, starter relay coil, passing (15A).
- c) Fuel pump, coils, injectors (20A).
- d) Lambda burner, secondary injection relay coil, starter relay coil, speed sensor power (15A).
- e) Permanent positive, ECU power (3A).

NOTE There are three spare fuses (3, 15, 20 A).

ARRANGEMENT OF MAIN FUSES

- f) From battery to voltage regulator (30A).
- g) From battery to key and C and D fuses (30A).

NOTE There is one spare fuse.

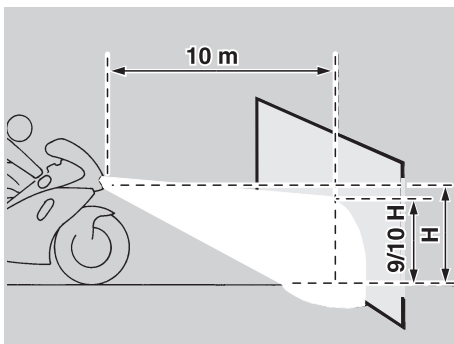

BEAM SETTING

NOTE Beam inspection procedures may vary from country to country. Observe the law in force in the country of the user.

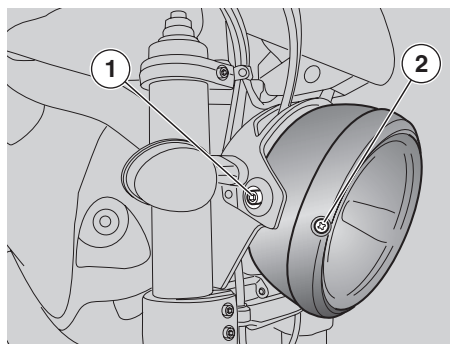

BEAM VERTICAL ADJUSTMENT

- ◆ Place the vehicle upright.
- ◆ Slightly loosen screws (1) fixing the headlight and manually adjust headlight beam to the desired position.
- ◆ Once finished, tighten screws (1).

⚠ CAUTION

On reassembly, tighten the screws (1) moderately to avoid damage to the plastic material.

After the adjustment:

⚠ WARNING

Check for correct beam horizontal setting.

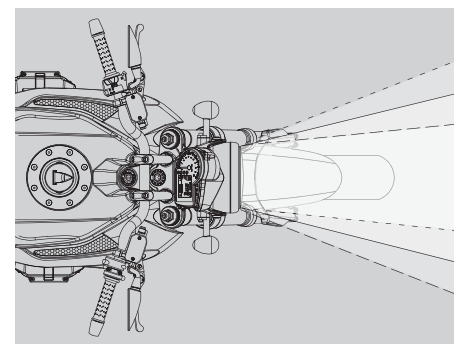

BEAM HORIZONTAL ADJUSTMENT

⚠ WARNING

Do not use the vehicle if the lights are not functioning properly. Do not use the vehicle if the headlight is adjusted incorrectly. This could temporarily blind oncoming cars and reduce the rider's ability to see obstacles along the road while riding at night. It is always advisable to reduce speed when riding at night, so as to have the time necessary to avoid any obstacle and to adapt to the poorer visibility that inevitably results from darkness. Failure to observe this warning can cause collision with another object, with consequent risk of serious injury or even death.

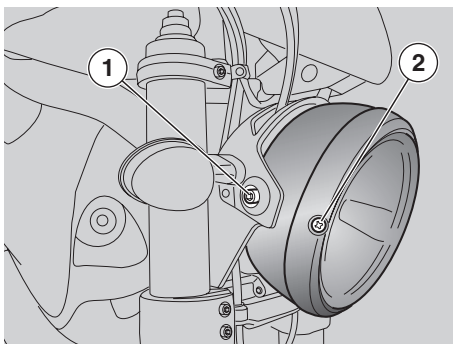

- ◆ Place the vehicle upright.
- ◆ Turn screw (2) to set headlight beam.

When finished:

⚠ WARNING

Make sure that the vertical adjustment of the headlight beam is correct. Different jurisdictions have different requirements for horizontal headlight beaming. Make sure that you comply with the rules of the jurisdiction where your vehicle is being used.

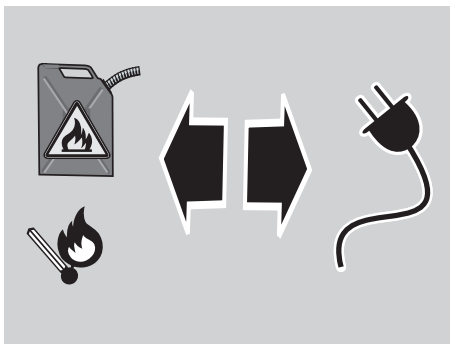

BULBS

Carefully read page 71 (MAINTENANCE).

⚠ WARNING

Do not use the vehicle if the lights are not functioning properly. Do not use the vehicle if the headlight is adjusted incorrectly. This could temporarily blind oncoming cars, and also reduce the rider's ability to see any obstacle along the road while riding at night.

It is always advisable to reduce speed when riding at night, so as to have the time necessary to avoid any obstacle and to adapt to the poorer visibility that inevitably results from darkness. Failure to observe this warning can cause you to collide with another object, with consequent risk of serious injury or even death.

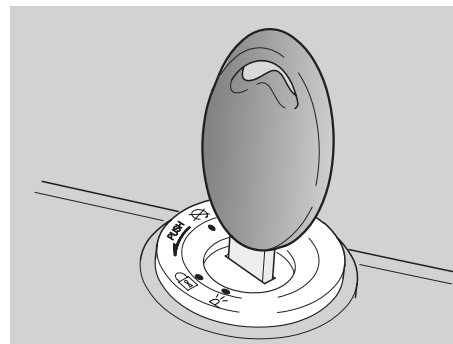

⚠ WARNING

Fire hazard.

Keep fuel and other flammable substances away from electric components.

⚠ CAUTION

Before proceeding to change a bulb, set the ignition switch to "OFF" and allow some time for the bulb to cool down.

Wear clean gloves or use a clean, dry cloth to handle the new bulb. Do not put your fingerprints on the bulb, as this may lead to overheating and failure.

If you have handled the bulb with bare hands, clean it with alcohol to avoid any damage.

DO NOT PULL ON THE WIRES.

NOTE Before changing a bulb, check the fuses, see page 93 (CHANGING THE FUSES).

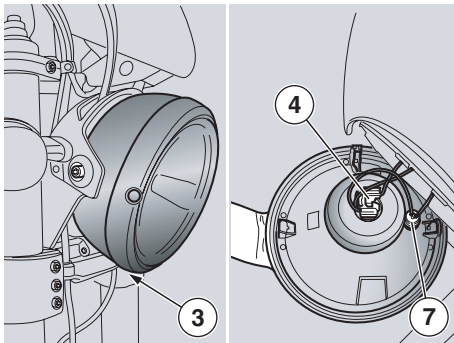

CHANGING THE HEADLIGHT BULBS

Carefully read page 96 (BULBS).

The headlight contains:

- one low/high beam bulb (1) (upper);
- one parking light bulb (2) (lower).

To change, proceed as follows:

- ◆ Place the vehicle on the stand, see page 50 (PUTTING THE VEHICLE ON THE STAND).
- ◆ To remove the complete reflector from headlight body, loosen the screw (3).

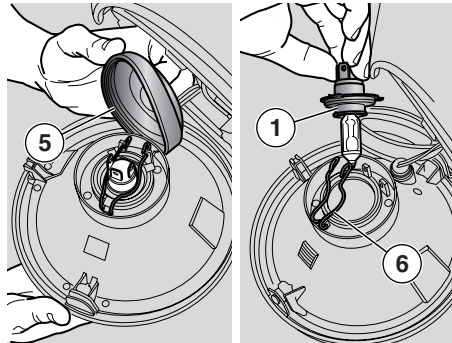

LOW/HIGH BEAM BULB

Do not pull on the wires to extract the bulb connector.

- ◆ Grasp the bulb connector (4) and pull to disconnect it from the bulb.
- ◆ Slip off the protection element (5) with your fingers.
- ◆ Unhook the two ends of the retaining spring (6) positioned on the bulb holder.
- ◆ Extract the bulb (1) from its seat.

NOTE Insert the bulb in the bulb holder, making the relevant positioning seats coincide.

- ◆ Fit a new bulb of equal rating.

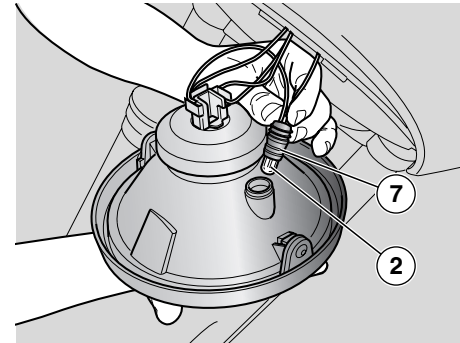

PARKING LIGHT BULB

⚠ CAUTION

To extract the bulb holder, do not pull the electric wires.

- ◆ Grasp the parking light (7) bulb holder and pull to extract.
- ◆ Withdraw the bulb (2) and replace it with one of the same type.
- ◆ Make sure the bulb is correctly located in the bulb holder.

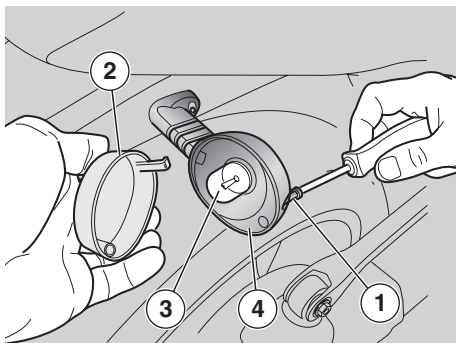

CHANGING THE FRONT AND REAR TURN INDICATOR BULBS

Carefully read page 96 (BULBS).

- ◆ Place the vehicle on the stand, see page 70 (PUTTING THE VEHICLE ON THE STAND).
- ◆ Unscrew and remove the screw (1).

⚠ CAUTION

While removing the lens, proceed carefully in order not to break the locating peg.

- ◆ Remove the lens (2).

⚠ CAUTION

Make sure that the lens locates correctly into its seat on refitting. Tighten the screw (1) moderately and carefully, to avoid damaging the lens.

- ◆ Press the bulb (3) slightly and rotate it anticlockwise.
- ◆ Extract the bulb (3) from its seat.

⚠ CAUTION

Insert the bulb into the bulb holder, so that the two pins slide into the slots in the holder.

- ◆ Fit a new bulb of equal rating.

⚠ CAUTION

If the bulb holder (4) comes off, refit it into its seat so that the chamfered opening of the holder matches the hole for the screw.

CHANGING THE TAIL LIGHT BULB

This vehicle fits a LED tail light, have it replaced by a **Moto Guzzi** Authorized Dealer.

REPLACING THE NUMBER PLATE BULB

Since this operation is quite complex, have it performed by a **Moto Guzzi** Authorized Dealer.

TRANSPORT



⚠ CAUTION

Never drain the fuel tank, either partially or completely. This may cause damage to the inner components of the fuel tank, or to other parts of the fuel system.

Always ensure that the fuel filler cap is correctly closed.

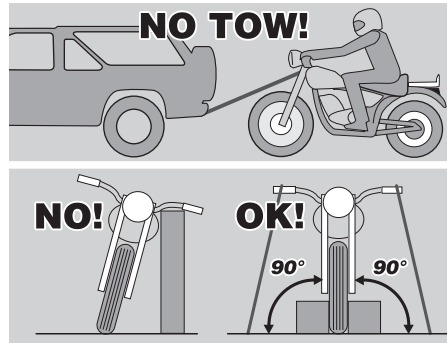

⚠ WARNING

Never attempt to tow your vehicle with another vehicle.

⚠ WARNING

While your vehicle is being transported, it must be kept in a vertical position, firmly tied down, and with the wheels blocked.

Transport your vehicle in neutral gear only.

Failure to heed this warning could cause serious damage to the transmission due to vibration of the transport truck.

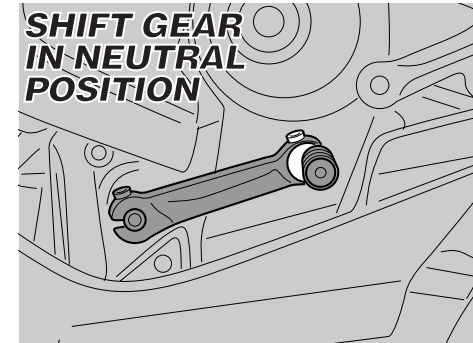

DRAINING THE FUEL TANK

⚠ CAUTION

Never drain the fuel tank, either partially or completely. This may cause damage to the inner components of the fuel tank, or to other parts of the fuel system.

Always ensure that the fuel filler cap is correctly closed.

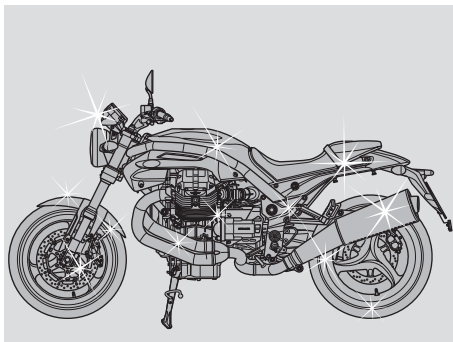

Clean your vehicle regularly. Your vehicle will look better and work better if you keep it clean. You will find you will need to clean it more frequently if it is used in the following conditions:

- Polluted areas (cities and industrial areas).
- Areas characterized by a high percentage of salinity and humidity (sea areas, hot and humid climates).
- Particular conditions (use of salt and anti-chemical products on the roads during the winter).
- ◆ Do not allow contaminants such as industrial dust, tar spots, dead insects, bird droppings, etc. to remain on the painted portions of your vehicle. They will very quickly etch into and damage the paint.
- ◆ Do not park your vehicle under trees, since some trees ooze resins that contain chemicals which can damage the paint.



⚠ WARNING

After your vehicle has been washed, the brake functioning will be temporarily impaired because of the wetness of the disks and pads. Do not ride in traffic until after you have dried the brakes by repeated braking from slow speed.

Always after washing your vehicle, carry out the preliminary checking operation, see p. 62 (PRE-RIDE CHECKS CHART).

⚠ CAUTION

To clean the lights, use a sponge soaked with water and a neutral detergent, rubbing the surfaces delicately and rinsing frequently with plenty of water.

Polish with silicone wax only after having carefully washed your vehicle.

Do not use polishing pastes on matt paints.

Do not wash the vehicle in direct sunlight, especially during the summer, when the paintwork is still warm, since if the shampoo dries before being rinsed away, it can damage the paint.

Do not use solvents or water hotter than 40°C to clean the plastic components of the vehicle.

Never use a high pressure washer, a steam cleaner, or an air augmented water jet to clean your vehicle, especially the wheel hubs, handlebar controls, brake reservoirs and cylinders, instruments, electrical components or exhaust silencer.

Such cleaning machinery will force water into critical portions of your vehicle, which could damage your vehicle through corrosion or short circuiting.

Do not use alcohol or gasoline or solvents to clean rubber and plastic parts. Use only clear water with a mild soap.

Do not use solvents or oil-derived fluids (such as acetone, trichloroethylene, turpentine, fuel, thinners) to clean the seat. You can use detergents with surface-active agents up to 5% (mild soap, degreasing agents or alcohol).

Carefully dry the seat when clean.

⚠ WARNING

Do not apply any protective coating to the saddle. Such coatings tend to make the saddle too slippery.

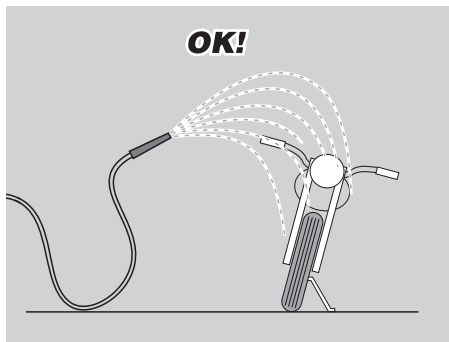

To remove dirt and mud from the painted surfaces, use a low pressure water hose. Apply water to dirty parts carefully and remove mud and dirt with a soft car sponge. You may use proprietary car shampoos (2-4% parts of shampoo in clear water) to make this easier.

Carefully rinse so that no dirt or grit remains on the paintwork, and dry with a clean chamois cloth or terry towel.

To clean the engine and other non-painted parts, use a mild solvent and a bristle brush along with plenty of rags.

Parts in anodized or painted aluminum such as forks, wheel rims, frame, footpegs and so on, should be washed with mild soap and water. Do not use harsh detergents or else the surface treatment of these parts might undergo damage.

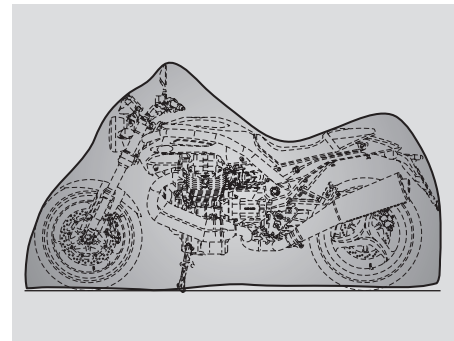

LONG PERIODS OF INACTIVITY

⚠ CAUTION

If the vehicle will not be ridden for more than twenty days, disconnect the 30A fuses to avoid deterioration of the battery.

NOTE Removing the 30A fuses resets the digital clock. To reset this function, see page 33 (MULTIFUNCTION COMPUTER).

When the vehicle will not be ridden for long periods, some precautions are necessary to avoid damage.

Do not postpone necessary repairs or you may forget them when you take the vehicle out of storage; a general check up is also recommended.

**OK OLD SHEET! OK MUFFLER PROTECTION!
OK LIGHT CANVAS!**

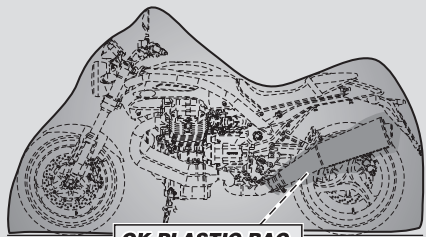

**OK PLASTIC BAG
FOR MUFFLER!**

To prepare the vehicle for storage:

- ◆ Remove the battery, see p. 90 (REMOVING THE BATTERY) and store it, see p. 89 (LONG INACTIVITY OF THE BATTERY).
- ◆ Wash and dry the vehicle, see p. 100 (CLEANING).
- ◆ Polish the painted surfaces with wax, see p. 100 (CLEANING).
- ◆ Inflate the tires, see p. 55 (TIRES).
- ◆ Do not drain the fuel tank. However, if available, you may wish to add a proprietary fuel storage additive available from your **Moto Guzzi** Authorized Dealer or from automobile supply stores. Follow the instructions on the container.

NOTE Do not add more than the recommended amount of additive.

⚠ CAUTION

Some fuel additives may damage some components of your fuel system. Check with your **Local Moto Guzzi Dealer**.

- ◆ Place the vehicle in a cool, dry room, away from direct sunlight, with minimum temperature variations.

⚠ WARNING

Before carrying out the following operations, let the engine and the exhaust silencer cool down until they reach room temperature. Failure to observe this warning can lead to serious burns.

- ◆ Place a plastic bag over the outlet pipe of the muffler, and tape or tie it tight.

NOTE You must use the appropriate support stands to store your vehicle so that both tires are raised from the ground.

- ◆ Cover the vehicle with an old sheet or a light canvas, do not use a sheet of plastic or other waterproof material. This will cause condensation which will result in corrosion.

PUTTING THE VEHICLE BACK INTO SERVICE

NOTE Remove the plastic bag from the outlet pipe of the muffler.

- ◆ Uncover and clean the vehicle, see p. 100 (CLEANING).
- ◆ Check the charge of the battery, see p. 91 (CHARGING THE BATTERY) and install it, see p. 92 (INSTALLING THE BATTERY).
- ◆ Carry out the preliminary checking operations, see p. 62 (PRE-RIDE CHECKS CHART).

⚠ WARNING

Test ride the vehicle at moderate speed in a low traffic area before you ride in heavy traffic.

TECHNICAL DATA

DIMENSIONS	Max. length	88.97 in (2260 mm)
	Max. width	34.64 in (880 mm)
	Max. height	41.12 in (1070 mm) (rear-view mirrors excluded)
	Seat height	31.49 in (800 mm)
	Distance between centres	61.18 in (1554 mm)
	Minimum ground clearance	7.28 in (185 mm)
	Weight in running order	529 lb (240 kg)
	ENGINE	Model
Type		90° traverse V-type, twin-cylinder, 4-stroke
Number of cylinders		2
Displacement		1064 cc
Bore/stroke		3.62x3.14 in (92x80 mm)
Compression ratio		9.8: 1
Starting		electric
Engine idling rpm		1100 ± 100 rpm
Clutch		twin-plate, dry
Lubrication system		pressure-fed system, adjustment through valves and lobe pump
Air filter		cartridge, dry
CAPACITIES	Cooling	air
	Fuel (reserve included)	4.54 US gal (17.2 ℓ)
	Fuel reserve	0.87 US gal (3.3 ℓ)
	Engine oil	oil and oil filter change 3600 cc
	Gearbox fluid	500 cc
	Transmission fluid	380 cc
	Fork fluid	520 ± 2.5 cu cm (per leg)
	Seats	2
Vehicle max. load	463 lb (210 kg) (rider + passenger + luggage)	

DRIVE RATIOS	Ratio	Primary	Final	Final ratio
	1st	gears	17/38	with universal joint
	2nd	24/35	20/34	12/44
	3rd		23/31	
	4th		26/29	
	5th		31/30	
	6th		29/25	
FUEL FEED SYSTEM	Type	sequential, timed, multipoint Magneti Marelli electronic injection IAW5A, alpha-n system; 2 1.57 in (40 mm) throttle bodies with Weber IW 031 injectors, lambda sensor		
	Throttle	Ø 1.41 in (36 mm)		
FUEL SUPPLY	Fuel	Premium-grade unleaded gasoline, minimum octane rating 95 (ROM) and 85 (MON).		
FRAME	Type	Tube frame with two cradles in high-strength steel		
	Steering head angle	26°30'		
	Trail	4.25 in (108 mm)		
SUSPENSIONS	Front	hydraulic telescopic upside-down fork, Ø 1.69 in (43 mm); adjustable spring preload, compression and rebound damping.		
	Wheel stroke	4.72 in (120 mm)		
	Rear	single-sided with progressive linkage, monoshock with adjustable rebound and compression damping and spring preload		
	Wheel stroke	4.33 in (110 mm)		
BRAKES	Front	twin floating disk in stainless steel Ø 12.59 in (320 mm), calliper with 4 separated pistons		
	Rear	stainless steel disk - Ø 11.10 in (282 mm), floating calliper with four parallel pistons		
WHEEL RIMS	Type	3 hollow spokes in aluminium alloy, chill cast		
	Front	3.5" x 17"		
	Rear	5.5" x 17"		
TIRES	Type	DUNLOP D208 RR - METZELER RENNSPORT - PIRELLI DIABLO CORSA - MICHELIN PILOT POWER		
	Front	Size: 120/70 - ZR 17" 58 W		
		Inflating pressure: 2.3 atm (230 kPa)		
		Inflating pressure with passenger: 2.3 atm (230 kPa)		

Rear

Size: 180/55 - ZR 17" 73 W

Inflating pressure: 2.5 atm (250 kPa)

Inflating pressure with passenger: 2.7 atm (270 kPa)

SPARK PLUGS

Inner (long life)	NGK PMR8B
Outer	NGK BPR6ES
Spark plug gap	0.023 – 0.027 in (0.6 – 0.7 mm)

ELECTRICAL SYSTEM

Battery	12 V – 18 Amp/h
Main fuses	30 A
Auxiliary fuses	3 A – 15 A – 20 A
Generator (with permanent magnet)	12 V – 550 W

BULBS

Parking light	12 V – 5 W
Low beam bulb/high beam	12 V – 55 W / 60W H4
Direction indicators	12 V – 10 W
Rear parking lights/Stoplight	LED
Instrument panel lighting	LED
Number plate light	12 V – 5 W

WARNING LIGHTS

Turn indicators	LED
Oil pressure	LED
Neutral	LED
Side stand down	LED
High beam	LED
Fuel reserve	LED
Alarm, gear shift indicator	LED

LUBRICANT CHART

(Recommended) Engine oil:  Agip RACING 4T 5 W 40.

As an alternative to recommended oils, top brand oils meeting or exceeding CCMC G-4 A.P.I. SG specifications can be used.

(Recommended) Transmission oil:  Agip TRUCK GEAR 80 W 90.

(Recommended) Gearbox oil:  Agip ROTRA MP/S 85 W 140.

(Recommended) Fork oil:  Agip FORK 5W or  Agip FORK 20W.

Bearings and other lubrication points (recommended):  Agip GREASE SM2.

As an alternative to recommended grease, use top brand rolling bearing grease that will resist a temperature range of -30°C +140°C, with dripping point 150°C - 230°C, high corrosion protection, good resistance to water and oxidisation.

Battery terminals protectant: Neutral grease or Vaseline.

WARNING

Use new brake fluid only. Do not mix different brands or types of oil unless you are sure that the different oil bases are compatible.

(Recommended) brake fluid: the system is loaded with  Agip BRAKE 5.1 DOT 4 (the braking system is also compatible with DOT 5).

As an alternative to the recommended product, top brand brake fluid meeting or exceeding SAE J1703, NHTSA 116 DOT 4, ISO 4925 specifications for synthetic brake fluid can be used.

Notes



ASK FOR GENUINE SPARE PARTS ONLY



AUTHORIZED DEALERS AND SERVICE CENTERS

THE VALUE OF SERVICE



Thanks to ongoing technical updates and product-specific technical training, **Moto Guzzi** Authorized Network engineers are familiar with every detail of this vehicle and have the special equipment required for correct maintenance and repair.

A vehicle kept in sleek running order is a reliable vehicle. Other key factors are pre-ride checks, proper maintenance at the recommended intervals and the use of **Moto Guzzi** Genuine Parts only!

To find contact information of the Authorized Dealer and/or Service Center nearest you, please consult the Yellow Pages or the map provided at our web site:

www.motoguzzi.it

When you demand **Moto Guzzi** Genuine Parts, you are purchasing products that have been developed and tested as early as the vehicle design stage. **Moto Guzzi** Genuine Parts systematically undergo strict quality control procedures to ensure total reliability and a long service life.

Moto Guzzi s.p.a. wishes to thank you for purchasing this vehicle and recommends the following:

- Do not release oil, fuel, polluting substances and components into the environment.
- Do not keep the engine running when not necessary.
- Avoid disturbing noise.
- Respect the environment.