

	VE	AR	G	VE-N
P				
LOCK				
OFF				
ON				

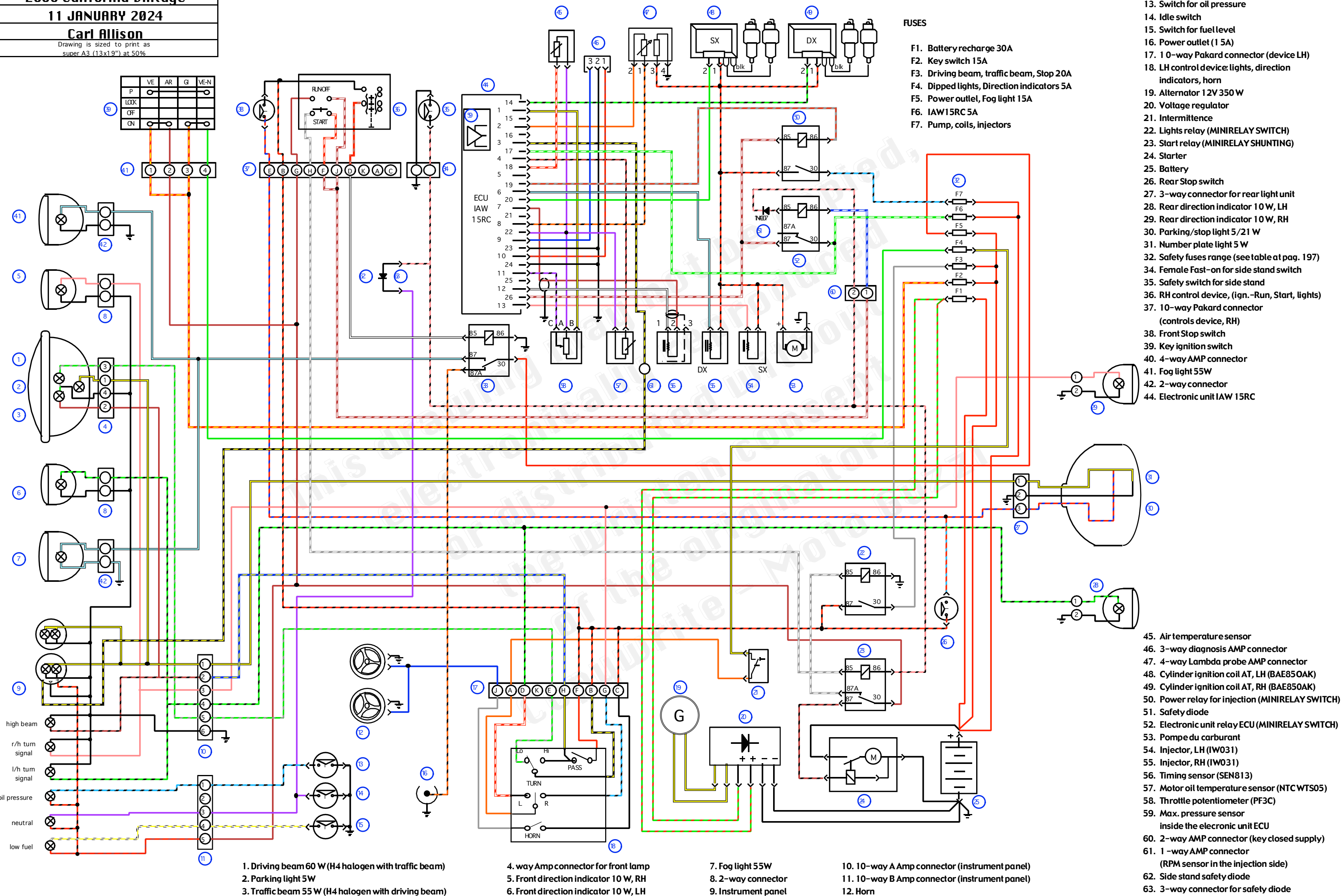

FUSES

- F1. Battery recharge 30A
- F2. Key switch 15A
- F3. Driving beam, traffic beam, Stop 20A
- F4. Dipped lights, Direction indicators 5A
- F5. Power outlet, Fog light 15A
- F6. IAW 15RC 5A
- F7. Pump, coils, injectors

- 13. Switch for oil pressure
- 14. Idle switch
- 15. Switch for fuel level
- 16. Power outlet (1 5A)
- 17. 1 0-way Pakard connector (device LH)
- 18. LH control device: lights, direction indicators, horn
- 19. Alternator 12V 350 W
- 20. Voltage regulator
- 21. Intermittence
- 22. Lights relay (MINIRELAY SWITCH)
- 23. Start relay (MINIRELAY SHUNTING)
- 24. Starter
- 25. Battery
- 26. Rear Stop switch
- 27. 3-way connector for rear light unit
- 28. Rear direction indicator 10 W, LH
- 29. Rear direction indicator 10 W, RH
- 30. Parking/stop light 5/21 W
- 31. Number plate light 5 W
- 32. Safety fuses range (see table at pag. 197)
- 34. Female Fast-on for side stand switch
- 35. Safety switch for side stand
- 36. RH control device, (ign.-Run, Start, lights)
- 37. 10-way Pakard connector (controls device, RH)
- 38. Front Stop switch
- 39. Key ignition switch
- 40. 4-way AMP connector
- 41. Fog light 55W
- 42. 2-way connector
- 44. Electronic unit IAW 15RC
- 45. Air temperature sensor
- 46. 3-way diagnosis AMP connector
- 47. 4-way Lambda probe AMP connector
- 48. Cylinder ignition coil AT, LH (BAE85OAK)
- 49. Cylinder ignition coil AT, RH (BAE85OAK)
- 50. Power relay for injection (MINIRELAY SWITCH)
- 51. Safety diode
- 52. Electronic unit relay ECU (MINIRELAY SWITCH)
- 53. Pompe du carburant
- 54. Injector, LH (IW031)
- 55. Injector, RH (IW031)
- 56. Timing sensor (SEN813)
- 57. Motor oil temperature sensor (NTC WTS05)
- 58. Throttle potentiometer (PF3C)
- 59. Max. pressure sensor inside the electronic unit ECU
- 60. 2-way AMP connector (key closed supply)
- 61. 1-way AMP connector (RPM sensor in the injection side)
- 62. Side stand safety diode
- 63. 3-way connector for safety diode

- 1. Driving beam 60 W (H4 halogen with traffic beam)
- 2. Parking light 5W
- 3. Traffic beam 55 W (H4 halogen with driving beam)

- 4. way Amp connector for front lamp
- 5. Front direction indicator 10 W, RH
- 6. Front direction indicator 10 W, LH

- 7. Fog light 55W
- 8. 2-way connector
- 9. Instrument panel

- 10. 10-way A Amp connector (instrument panel)
- 11. 10-way B Amp connector (instrument panel)
- 12. Horn